

# DIMEHO

DIFFUSION MÉDICALE HOSPITALIÈRE

## ÉQUIPEMENT MÉDICAL

Rail médical  TECHNOLOGIE  
MÉDICALE





- 6 RILSANISATION**  
RILSAN® COATING
- 7 GAMME DE COULEURS**  
RANGE OF COLOURS
- 8 RAIL MURAL, FIXATIONS ET EMBOUTS**  
WALL RAIL, FIXINGS AND END-CAPS
- 10 SYSTEME DE RAILS MOBILES**  
ADJUSTABLE RAILS SYSTEM
- 12 ATTACHES UNIVERSELLES  
POUR ACCESSOIRES**  
UNIVERSAL CLAMPS FOR ACCESSORIES
- 14 CROCHETS SUPPORT TUBULURES**  
TUBE HOLDERS
- 15 PORTE-DOCUMENTS**  
NOTES HOLDERS
- 16 PANIERS DE STOCKAGE**  
STORAGE BASKETS
- 17 CONTENEURS DE SONDÉS**  
CATHETER BASKETS
- 18 PANIERS POUR BOCAUX**  
BASKETS FOR JARS AND BOTTLES
- 20 TABLETTES ET CONSOLES**  
SHELVES AND CONSOLE TABLES
- 23 PORTE-A-FAUX**  
CANTILEVER
- 24 BLOCS CHEVET MODULABLES**  
ADJUSTABLE DRAWER UNITS





- 25 **PORTE-SONDES**  
CATHETER HOLDERS
- 26 **SUPPORT BOITE A GANTS**  
GLOVE BOX HOLDER
- 27 **PORTE-SACHETS D'EXAMEN**  
**PORTE-SAC A DECHETS**  
SPECIMEN BAG HOLDER  
RUBBISH BAG BASKETS
- 28 **PORTE-SAC POUBELLE**  
RUBBISH BAG HOLDERS
- 29 **PORTE-SERUM**  
DRIP STANDS
- 30 **POTENCES MURALES**  
WALL ARM HOOKS
- 31 **BARRES DE SUPPORT**  
**POUR POUSSE-SERINGUES**  
SUPPORT POLE FOR SYRINGE PUMPS
- 32 **PORTE-BOUTEILLE**  
CYLINDER HOLDER
- 33 **TENSIOMETRES**  
SPHYGMOMANOMETERS
- 34 **FLEXIBLES POUR TUBE D'AEROSOLS**  
FLEXIBLE RODS FOR AEROSOLS TUBES







# RILSANISATION

## RILSAN® COATING

Les accessoires de rail de la division GAUCHARD MEDICAL® / MEDIRAIL® sont revêtus d'une couche de Rilsan®.

### Qu'est ce que le Rilsan® ?

Le Rilsan®, le plus performant des revêtements plastiques pour le métal, est utilisé dans de nombreuses industries et très largement dans le domaine médical. Issu d'une matière première d'origine végétale renouvelable, il ne génère ni pollution ni odeur. Le revêtement de notre matériel est réalisé par projection électrostatique. L'épaisseur déposée peut varier de 30 à 250 microns et l'épaisseur courante est de 100 microns.

### Propriétés

**Propriétés physiques :** Résistance thermique, aux moisissures et aux champignons, à l'humidité et aux brouillards salins.

**Propriétés chimiques :** Inertie remarquable vis-à-vis d'un grand nombre de produits chimiques, détergents, solvants usuels, produits alimentaires.

**Propriétés électriques :** Bonnes propriétés isolantes, même en milieu humide.

**Propriétés mécaniques :** Résistance à l'abrasion 500 à 600 fois supérieure à celle des peintures les plus résistantes. La densité et l'élasticité du plastique lui permettent d'amortir les chocs et lui confèrent ainsi une haute résistance aux pressions et à la corrosion. Autoclavable à 136 °C.

Disponible dans un large choix de couleurs, le revêtement rilsanisé apporte au matériel solidité et durabilité, ainsi qu'un aspect de surface esthétique et agréable au toucher.

**Entretien :** Ne jamais utiliser d'éponges abrasives, de poudres récurrentes et de diluants solvants (acétone, trichloréthylène).

GAUCHARD MEDICAL® / MEDIRAIL® rail accessories are Rilsan® coated.

### What is Rilsan®?

Rilsan®, the best plastic coating for metal products, has a wide variety of applications and is commonly used within the medical industry. Resulting from a natural and renewable raw material, it entails neither pollution nor odour. Our equipment is coated using an electrostatic discharge process which allows accurate coating thickness from 30 to 250 microns, 100 microns being the most common coating thickness.

### Properties

**Physical properties:** High resistance to heat, mould and mildew, humidity and salt spray.

**Chemical properties:** Outstanding resistance to most chemicals, detergents, common solvents and food.

**Electrical properties:** Excellent insulator, even in humid environments.

**Mechanical properties:** Very high resistance to abrasion (500 to 600 times better than the most resistant paints). Shocks are softened thanks to the plastic density and resiliency.

High pressure and corrosion resistance. Autoclavable up to 136 °C (276 °F).

Available in a large choice of colours, Rilsan® coating ensures an excellent strength and durability to the equipment, as well as a high quality and pleasant-to-the-touch finish.

**Cleaning:** Never use any type of abrasive sponge, scouring powder or thinner solvent (acetone, trichlorethylene).

### Quels sont les avantages ?

- Bonnes propriétés hygiéniques
- Ne favorise pas la prolifération bactérienne
- Compatibilité au contact alimentaire
- Facilité d'entretien
- Durabilité
- Anti-corrosion
- Résistance à l'abrasion et aux chocs
- Résistance à la chaleur
- Bonne isolation électrique
- Finition esthétique
- Gamme variée de couleurs

### What are the benefits ?

- Good hygienic properties
- Does not promote bacterial proliferation
- Food compatibility
- Easy-to-clean
- Durability
- Corrosion resistance
- Abrasion and shock resistance
- Heat resistance
- Good electrical insulation
- Attractive finish
- Wide range of colours





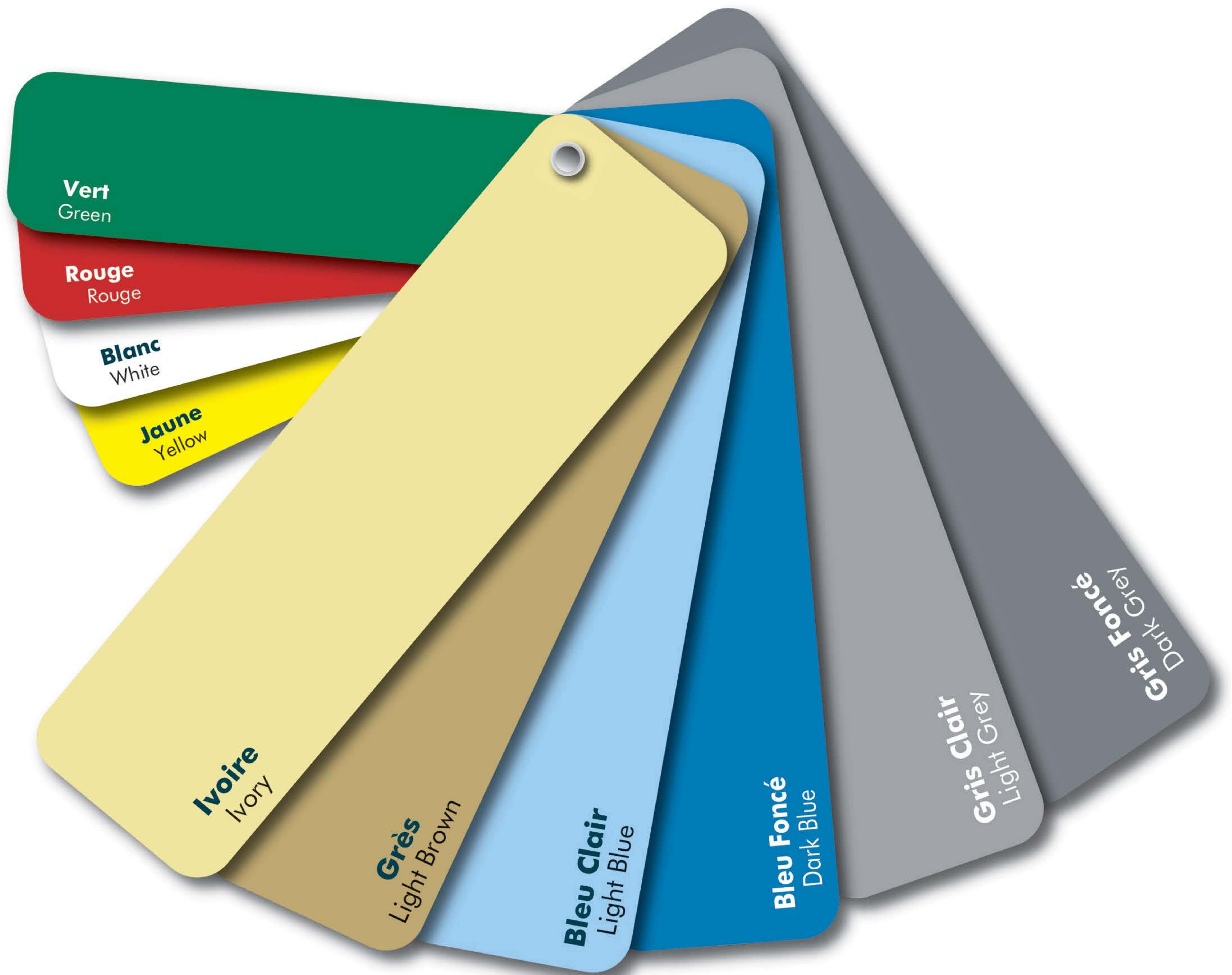

# UNE GAMME DE COULEURS ATTRAYANTES

## A RANGE OF ATTRACTIVE COLOURS

Nos accessoires sont disponibles dans les couleurs ci-dessus  
Our accessories are available in the above colours

N'hésitez pas à nous consulter pour toute précision ou demande spécifique !  
Do not hesitate to contact us if you have specific requirements!





# RAIL MURAL, FIXATIONS ET EMBOUTS

## Rail / Wall rail

### 15606

- Rail seul, sans fixation ni embout, aluminium anodisé
- Wall rail only, without fixing and end-cap, anodised aluminium

### 15626

- Rail seul, sans fixation ni embout, par longueur de 3,65 m maximum (perte de 10 cm)
- Wall rail only, without fixing and end-cap, for 3.65 m length maximum (loss of 10 cm)

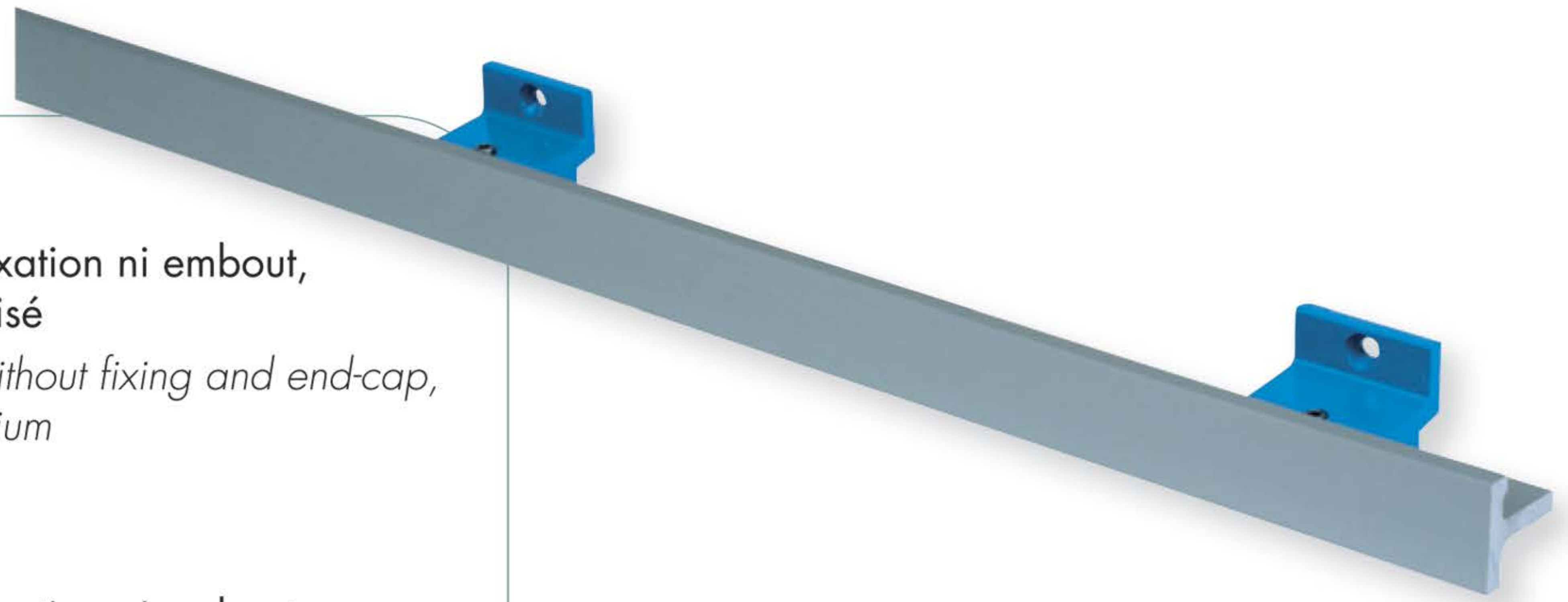

## Fixations murales / Wall rail fixings

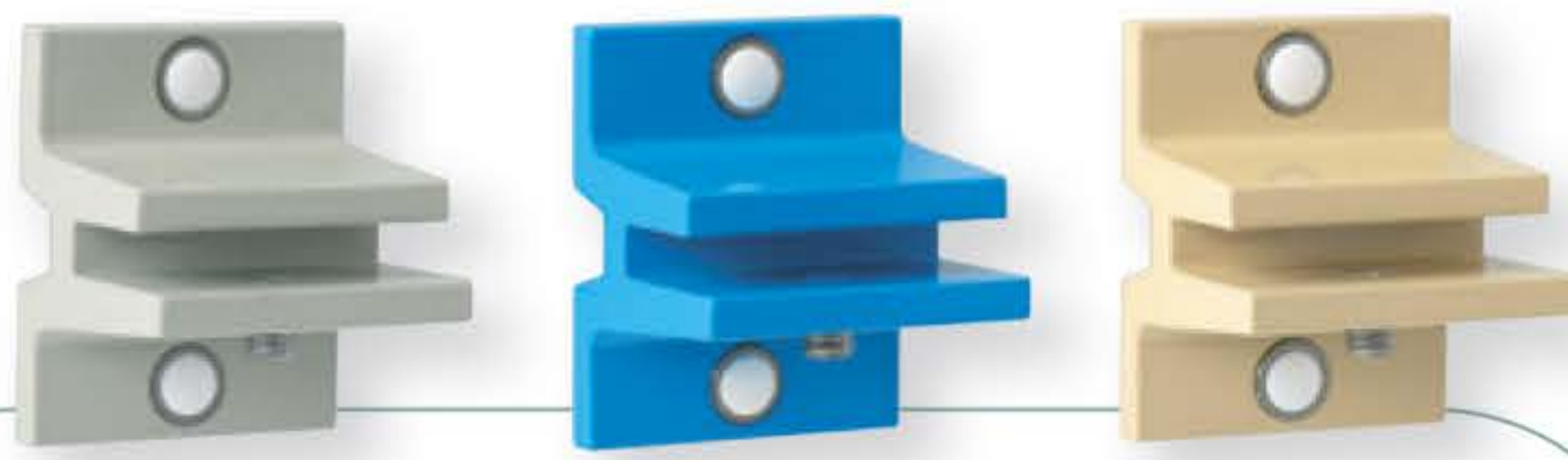

### 15611



### 15612



### 15614



- Fixation murale **standard**, 50 mm, rilsanisée, avec vis STHC 8 x 8
- *Standard duty wall rail fixing, 50 mm, Rilsan coated aluminium, with 8x8 hollow hexagonal headless stainless steel screws*

### 15619



### 15620



### 15622



- Fixation murale **haute résistance**, 80 mm, rilsanisée, avec vis STHC 8 x 8
- *Heavy duty wall rail fixing, 80 mm, Rilsan coated aluminium, with 8x8 hollow hexagonal headless stainless steel screws*



Cheilles, vis et cache-vis à commander séparément  
Anchors, screws and caps to be ordered separately

## Embouts de protection / PVC Rail end-caps

### 15528



### 15529



### 15530



### 15531

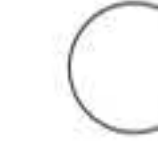

### 15533

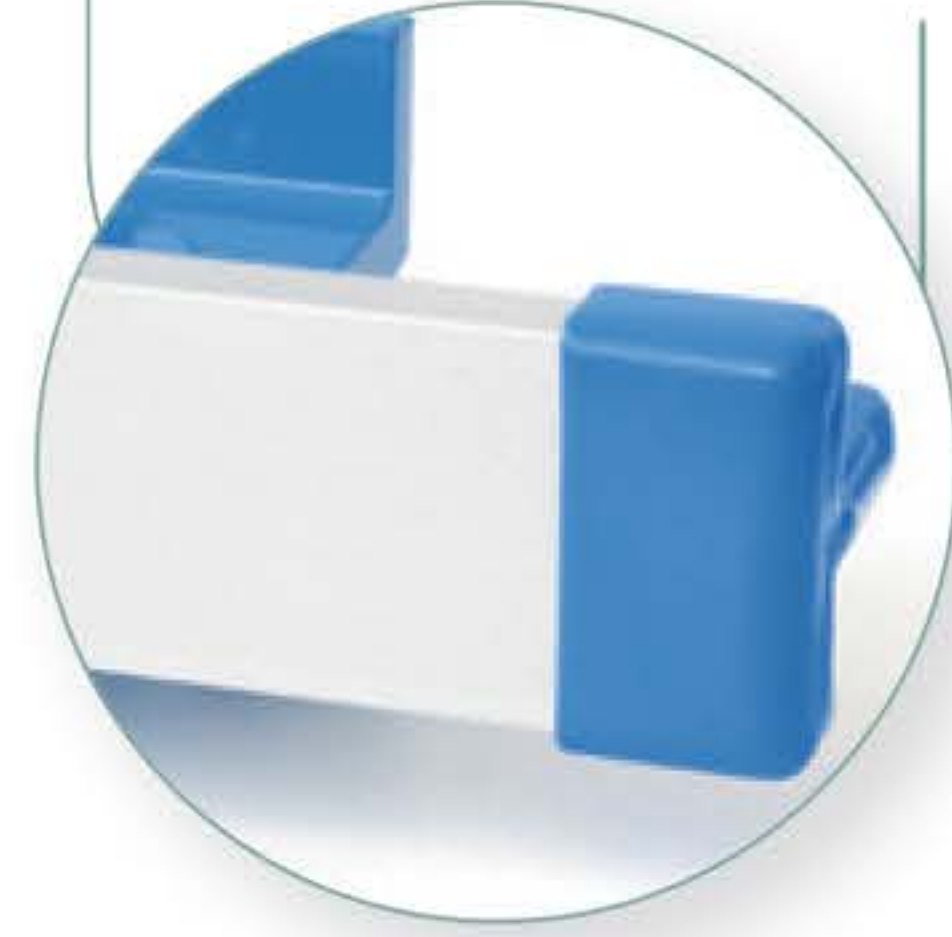

## Vis & Chevilles / Screws and anchors

### 16356

- Vis inox TFHC 6 x 50 pour chevilles de fixation, avec cache-vis plastique\*
- *Stainless steel hollow hexagonal countersunk head screw, 6 x 50 for fixing anchors, with plastic screw cover\**

### 18072

- Vis inox TFHC M 6 x 60 pour chevilles de fixation, avec cache-vis plastique – cloison double BA13
- *Stainless steel hollow hexagonal countersunk head screw, M 6 x 60 for fixing anchors, with plastic screw cover\* (double wall - BA 13 gypsum board)*

### 16292

- Capuchon cache-vis, plastique blanc, pour vis TFHC M6\*
- *White plastic screw cover for M6 hollow hexagonal countersunk head screw\**

### 16331

- Cheville "RB" M6 pour matériaux pleins
- *M6 anchor, model "RB" for solid base material*

### 16334

- Cheville "RN" M 6 x 35 pour cloison simple BA13
- *M 6 x 35 anchor, model "RN" for single wall - BA13 gypsum board*

### 16335

- Cheville "SN" M 6 x 65 pour cloison simple BA13
- *M 6 x 65 anchor model "SN" for single wall - BA13 gypsum board*

### 17677

- Cheville "RN" M 6 x 50 pour cloison double BA13
- *M 6 x 50 anchor, model "RN" for double wall - BA 13 gypsum board*

### 19794

- Cheville "SN" M 6 x 52 pour cloison simple BA13
- *M 6 x 52 anchor, model "SN" for single wall - BA 13 gypsum board*

\* Minimum de commande : 10 pièces

\* Minimum quantity to be ordered: 10 pieces





# RAIL MURAL, FIXATIONS ET EMBOUTS

WALL RAIL, FIXINGS AND END-CAPS

Comment passer votre commande ?

How to place your order ?

Rail / Rail	Quantité / Quantity			
Longueur (mm) Length (mm)	Fixations Fixings	Vis Screws	Cheilles Anchors	Embout End-caps
Minimum 500	2	4	4	2
750	2	4	4	2
1000	2	4	4	2
1250	3	6	6	2
1500	3	6	6	2
1750	3	6	6	2
2000	4	8	8	2
2250	4	8	8	2
2500	4	8	8	2
2750	5	10	10	2
3000	5	10	10	2
3250	5	10	10	2
Maximum 3500	6	12	12	2

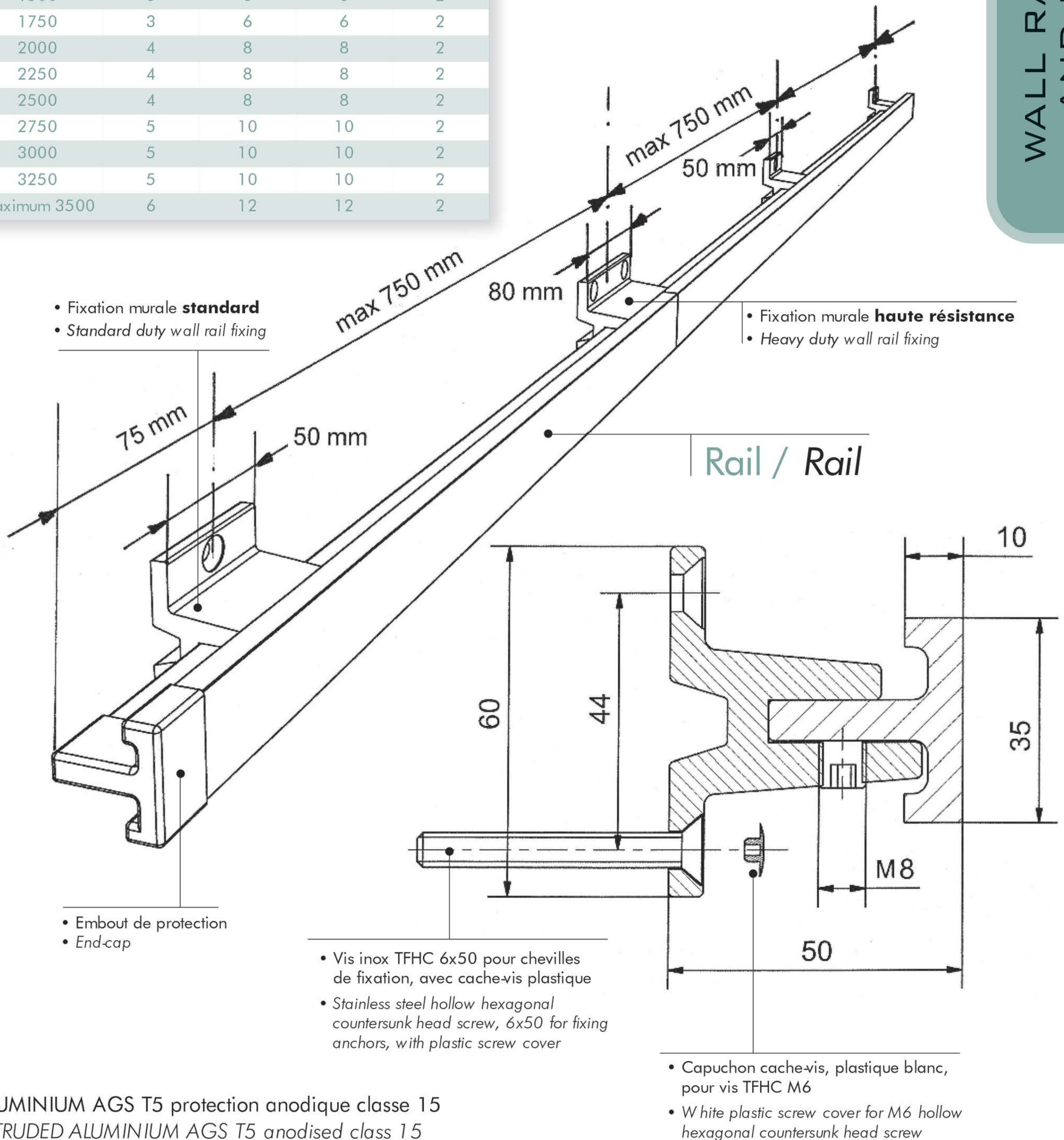

ALUMINIUM AGS T5 protection anodique classe 15  
EXTRUDED ALUMINIUM AGS T5 anodised class 15

Norme Européenne NF EN ISO 19054 / European standard NF EN ISO 19054





# SYSTEME DE RAILS MOBILES

ADJUSTABLE  
RAILS SYSTEM



## 15764

- Rail vertical seul pour système mobile, longueur 1,50 m, seul, avec 4 perçages, aluminium anodisé
- Vertical rail only for adjustable system, 1.5 m length with 4 piercings, anodised aluminium

Ce système permet de déplacer le rail horizontal en hauteur. Il peut être utilisé en présence de cloisons faibles.

*This system enables you to move the horizontal rail up and down. It can also be used for hollow walls.*

## 15741



## 15742



## 15744



- Fixation mobile DROITE, rilsanisée, avec vis STHC 8 X 8
- Wall rail fixing for adjustable system, with tightening mechanism on the RIGHT hand side, Rilsan coated aluminium, with 8x8 hollow hexagonal headless stainless steel screw

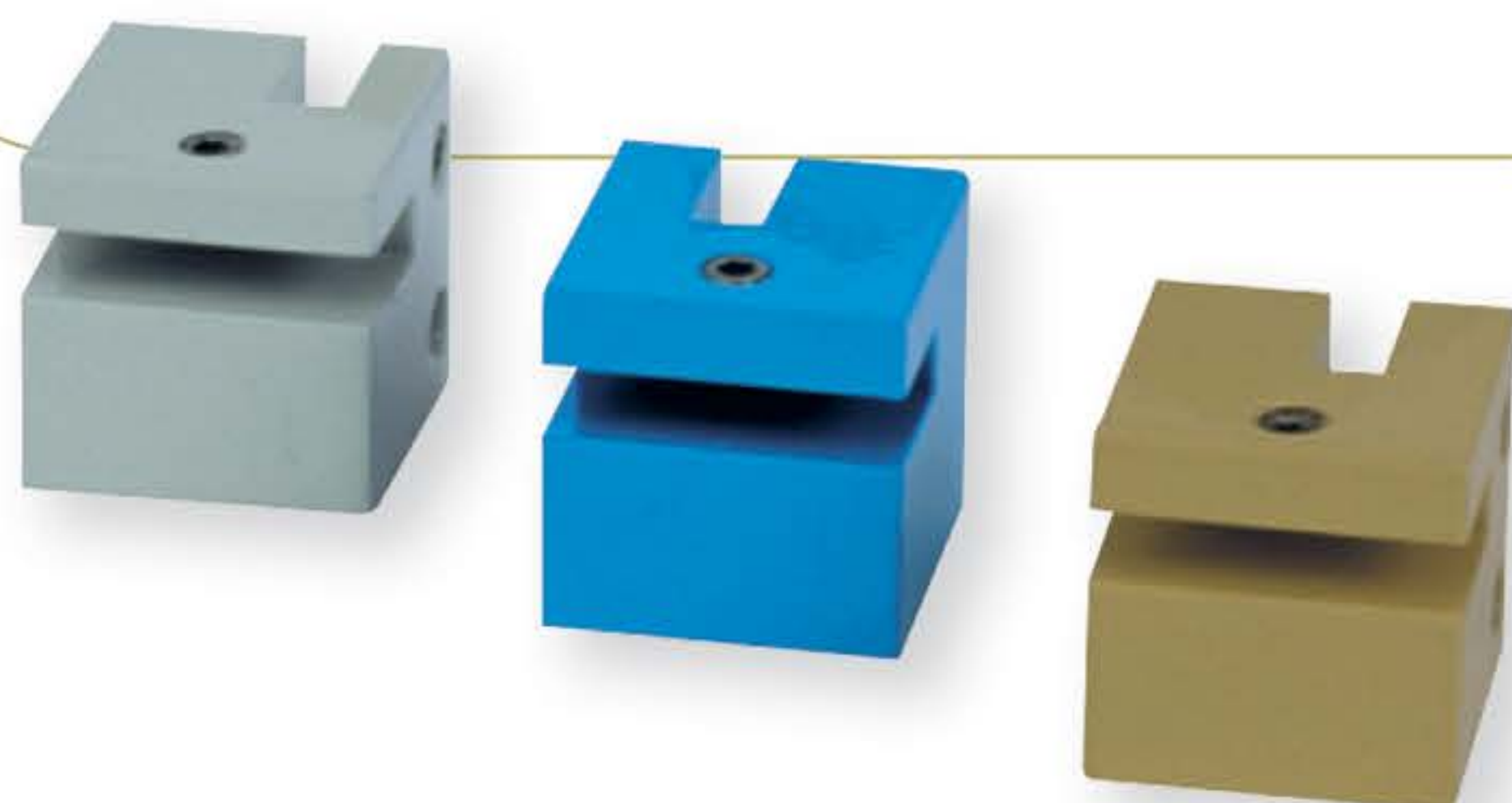

## 15752



## 15753



## 15754



- Fixation mobile DOUBLE rilsanisée pour jonction de 2 rails, avec vis STHC 8 X 8
- DOUBLE wall rail fixing for adjustable system to join two rails, Rilsan coated aluminium, with 8x8 hollow hexagonal headless stainless steel screw



## 15747



## 15748



## 15750



- Fixation mobile GAUCHE, rilsanisée, avec vis STHC 8 X 8
- Wall rail fixing for adjustable system, with tightening mechanism on the LEFT hand side, Rilsan coated aluminium, with 8x8 hollow hexagonal headless stainless steel screw

10

Chevilles, vis et cache-vis à commander séparément  
Anchors, screws and caps to be ordered separately





# SYSTEME DE RAILS MOBILES

## ADJUSTABLE RAILS SYSTEM

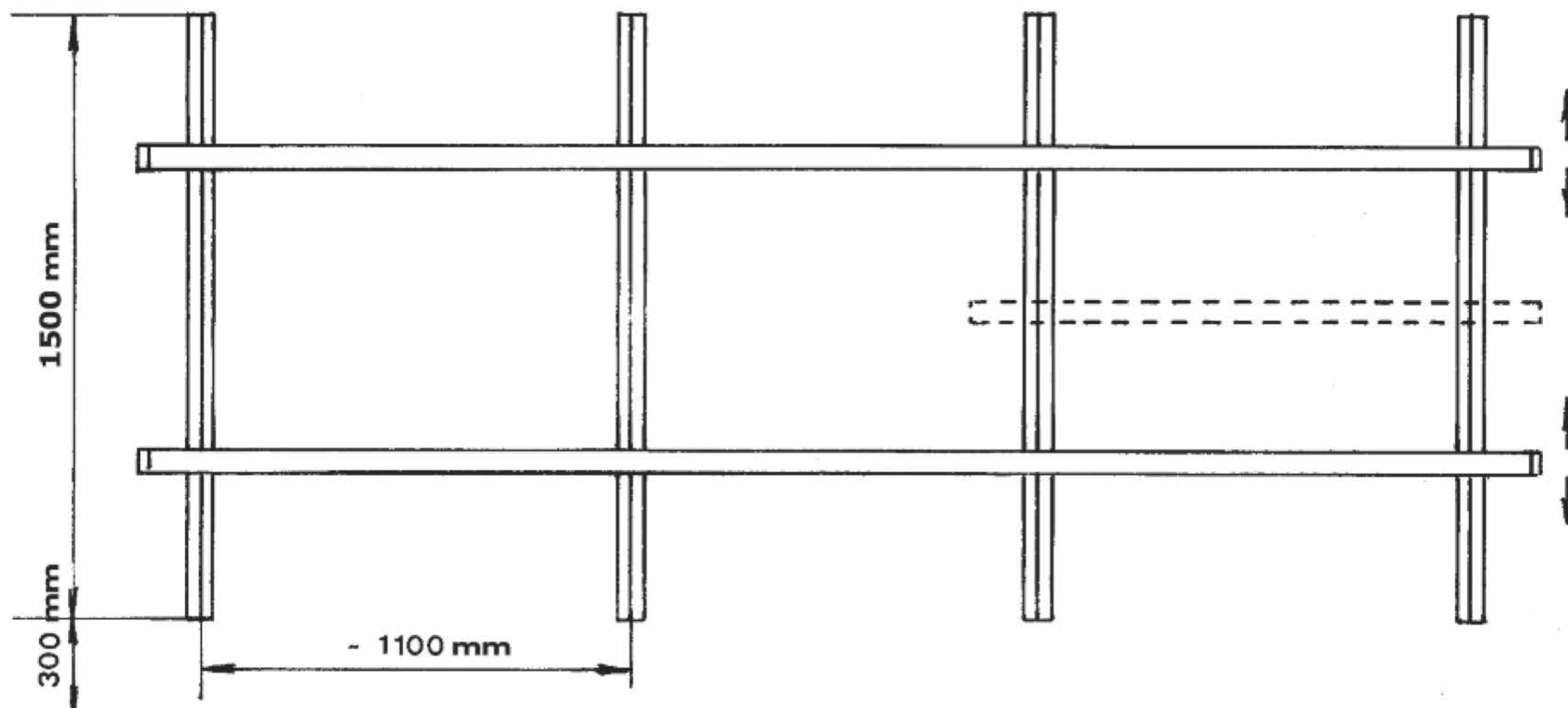

- Fixation mobile gauche
- Wall rail fixing for adjustable system, with tightening mechanism on the left hand side

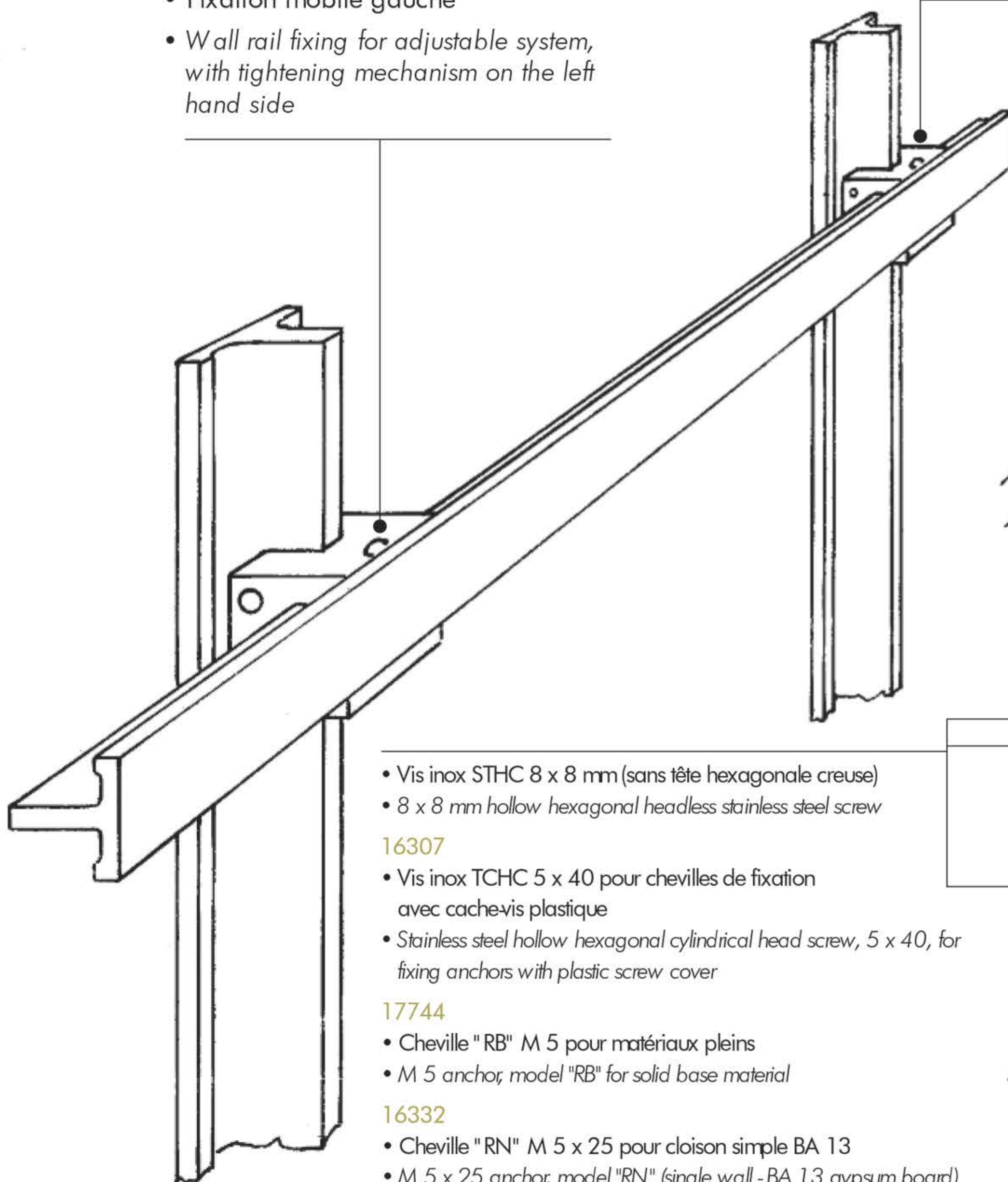

- Vis inox STHC 8 x 8 mm (sans tête hexagonale creuse)
- 8 x 8 mm hollow hexagonal headless stainless steel screw

16307

- Vis inox TCHC 5 x 40 pour chevilles de fixation avec cache-vis plastique
- Stainless steel hollow hexagonal cylindrical head screw, 5 x 40, for fixing anchors with plastic screw cover

17744

- Cheville "RB" M 5 pour matériaux pleins
- M 5 anchor, model "RB" for solid base material

16332

- Cheville "RN" M 5 x 25 pour cloison simple BA 13
- M 5 x 25 anchor, model "RN" (single wall - BA 13 gypsum board)

17741

- Cheville "RN" M 5 x 39.8 pour cloison double BA 13
- M 5 x 39.8 anchor, model "RN" (double wall - BA 13 gypsum board)

19796

- Cheville "SN" M 6 x 65 pour cloison double BA 13
- M 6 x 65 anchor, model "SN" (double wall - BA 13 gypsum board)

19795

- Chevilles "SN" M 5 x 37 pour cloison simple BA 13
- M 5 x 37 anchor, model "SN" (single wall - BA 13 gypsum board)

- Fixation mobile droite
- Wall rail fixing for adjustable system, with tightening mechanism on the right hand side

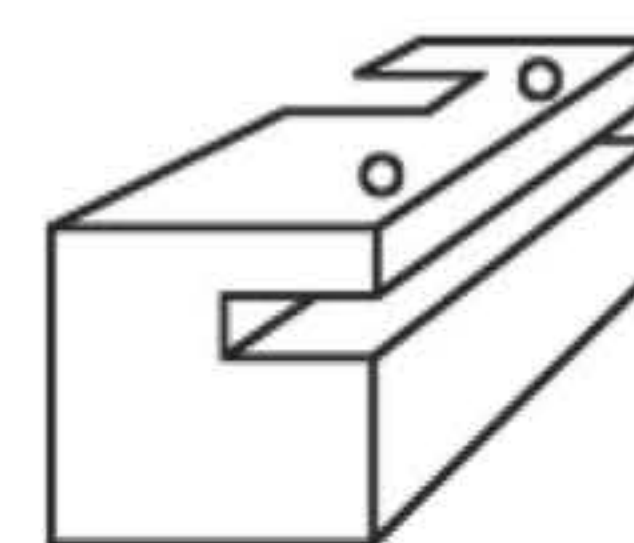
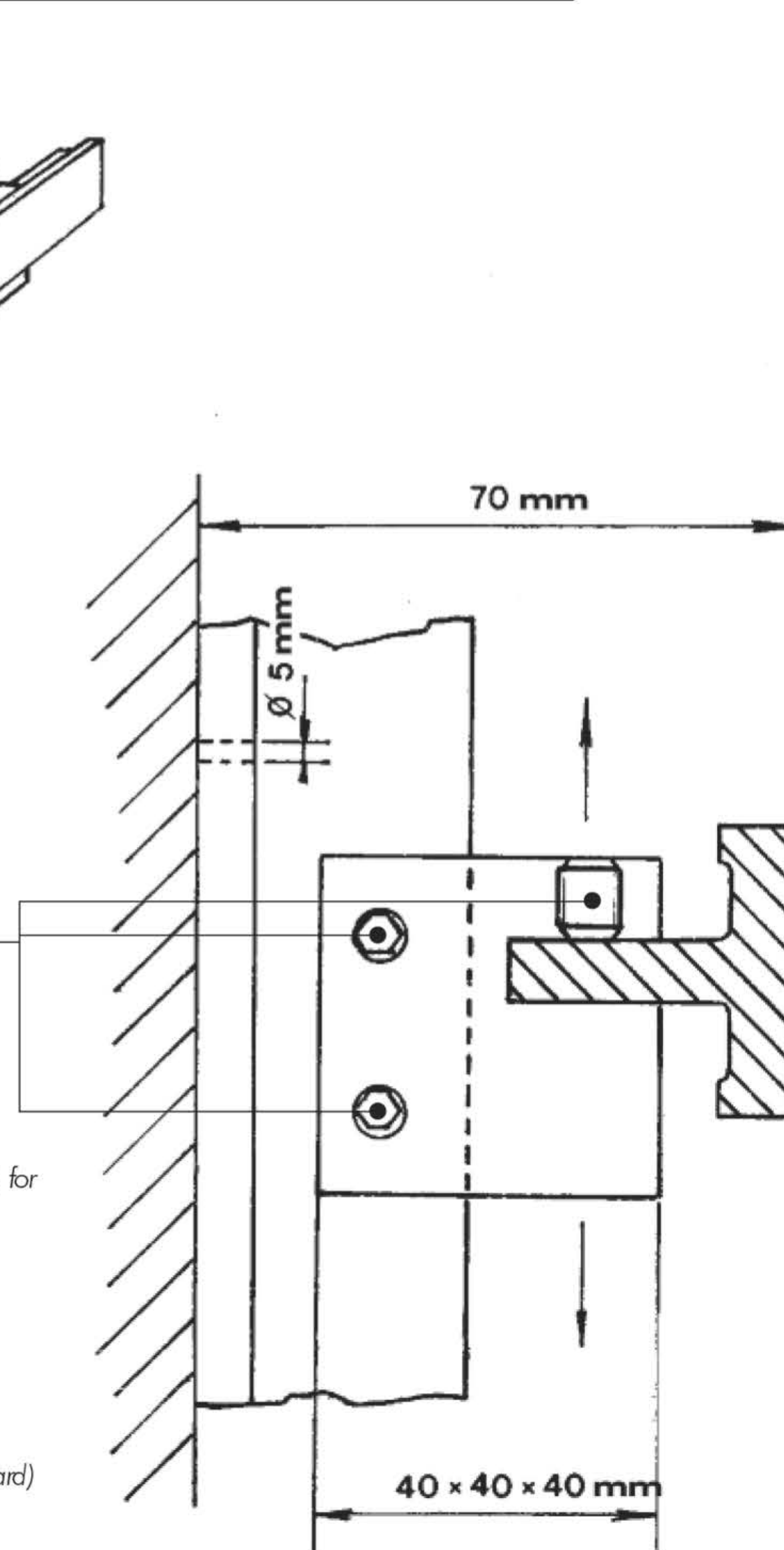

- Fixation mobile double, pour jonction de 2 rails
- Wall rail fixing for adjustable system, to join 2 rails





# ATTACHES UNIVERSELLES POUR ACCESSOIRES

UNIVERSAL CLAMPS  
FOR ACCESSORIES

## Attaches standard / Standard clamps

15665 | 15666 | 15667



- Attache universelle, modèle "A"
- *Universal standard clamp model A*

15670 | 15671 | 15672



- Attache universelle, modèle "ABX"
- *Universal standard clamp model ABX*

15674 | 15675 | 15676



- Attache universelle, modèle "E"
- *Universal standard clamp model E*

15679 | 15680 | 15681



- Attache universelle, modèle "GL"
- *Universal standard clamp model GL*

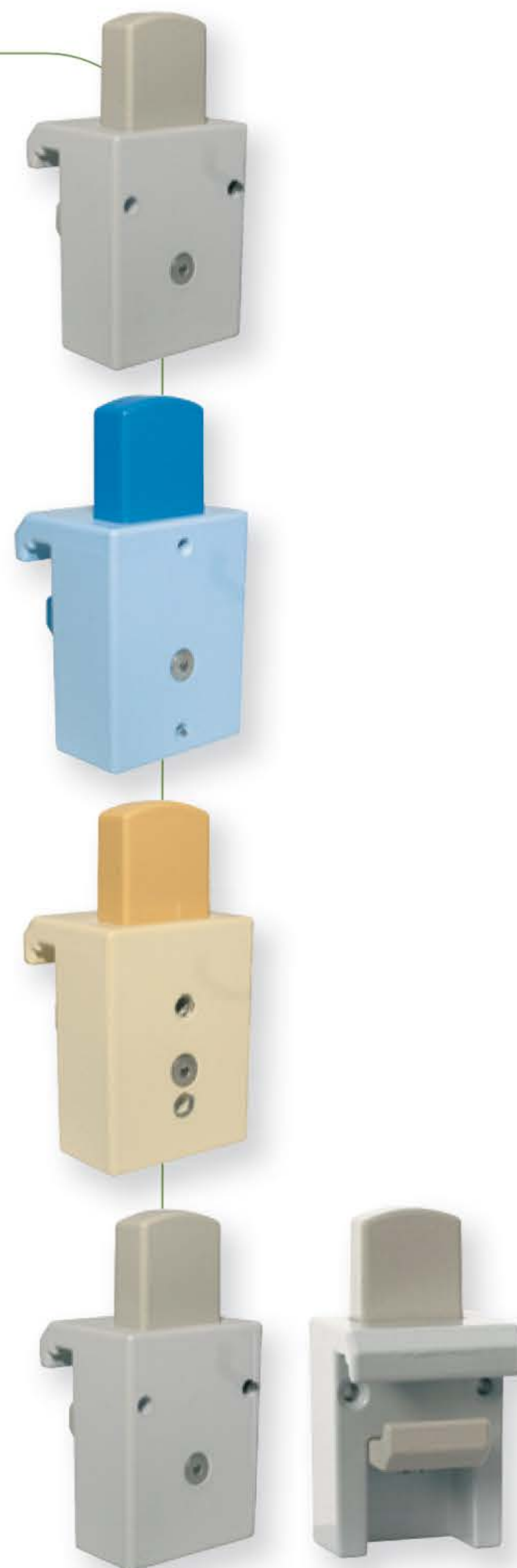

Perçages différents selon les modèles  
*Holes position depending on model*

## Attaches haute résistance / heavy duty clamps

15696 | 15697 | 15698



- Attache universelle à blocage **haute résistance**, modèle "A"
- *Universal heavy duty clamp with locking screw model A*

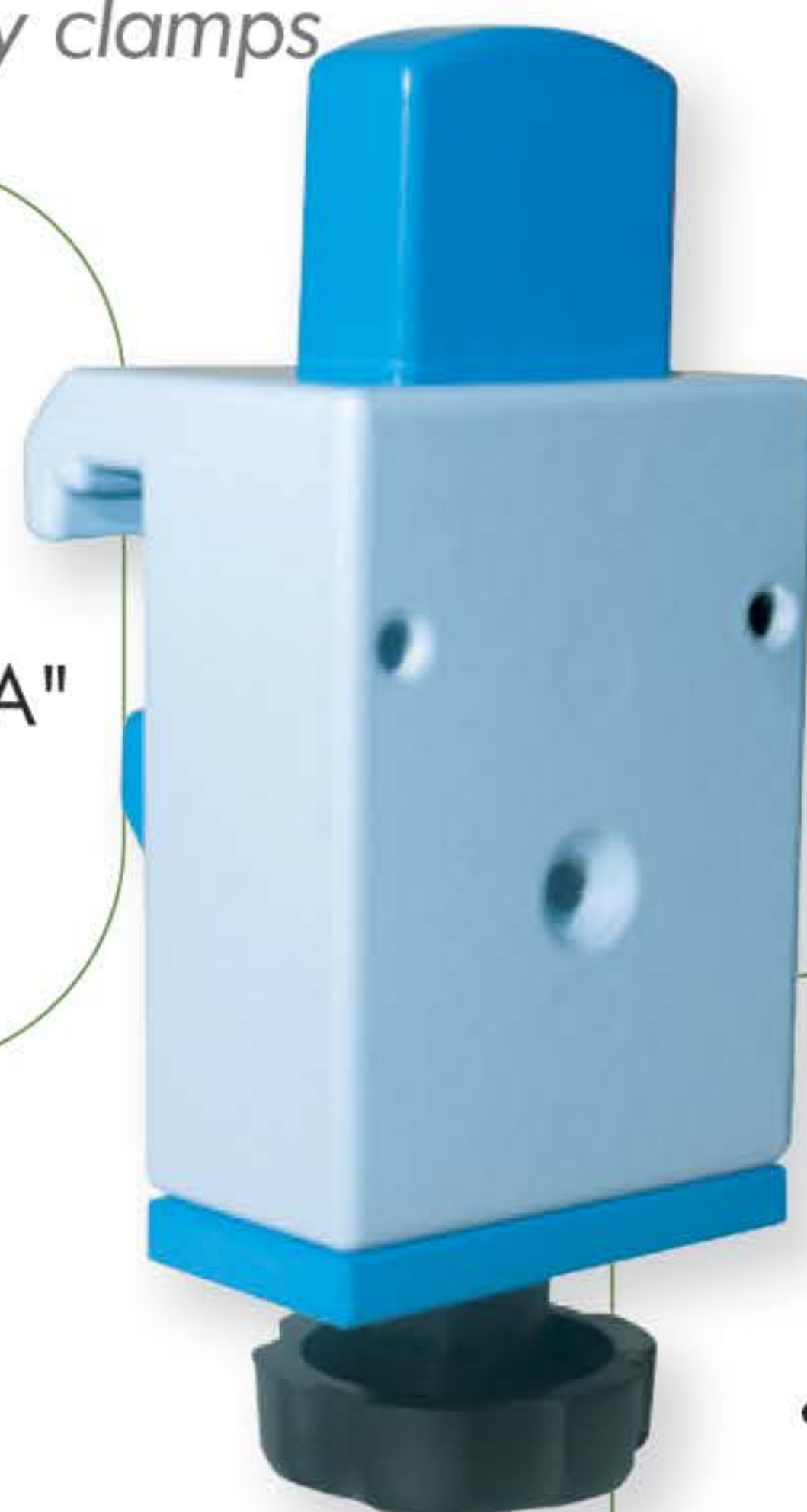

15699 | 15700 | 15701



- Attache universelle à blocage **haute résistance**, modèle "GL"
- *Universal heavy duty clamp with locking screw model GL*





# ATTACHES UNIVERSELLES POUR ACCESSOIRES

UNIVERSAL CLAMPS  
FOR ACCESSORIES

15653



15654



15655



- Attache universelle à glissière 45 x 5 mm pour bocal à usage unique, porte-bécher et porte-poubelle
- *Universal clamp with mounting slot 45 x 5 mm for single-use jar, beaker holder and rubbish bag holder*



15657



- Attache universelle à glissière 26 x 6 mm
- *Universal clamp with mounting slot 26 x 6 mm*



15662



15663



15664



- Support pour cables, attache universelle
- *Cables support with universal clamp*

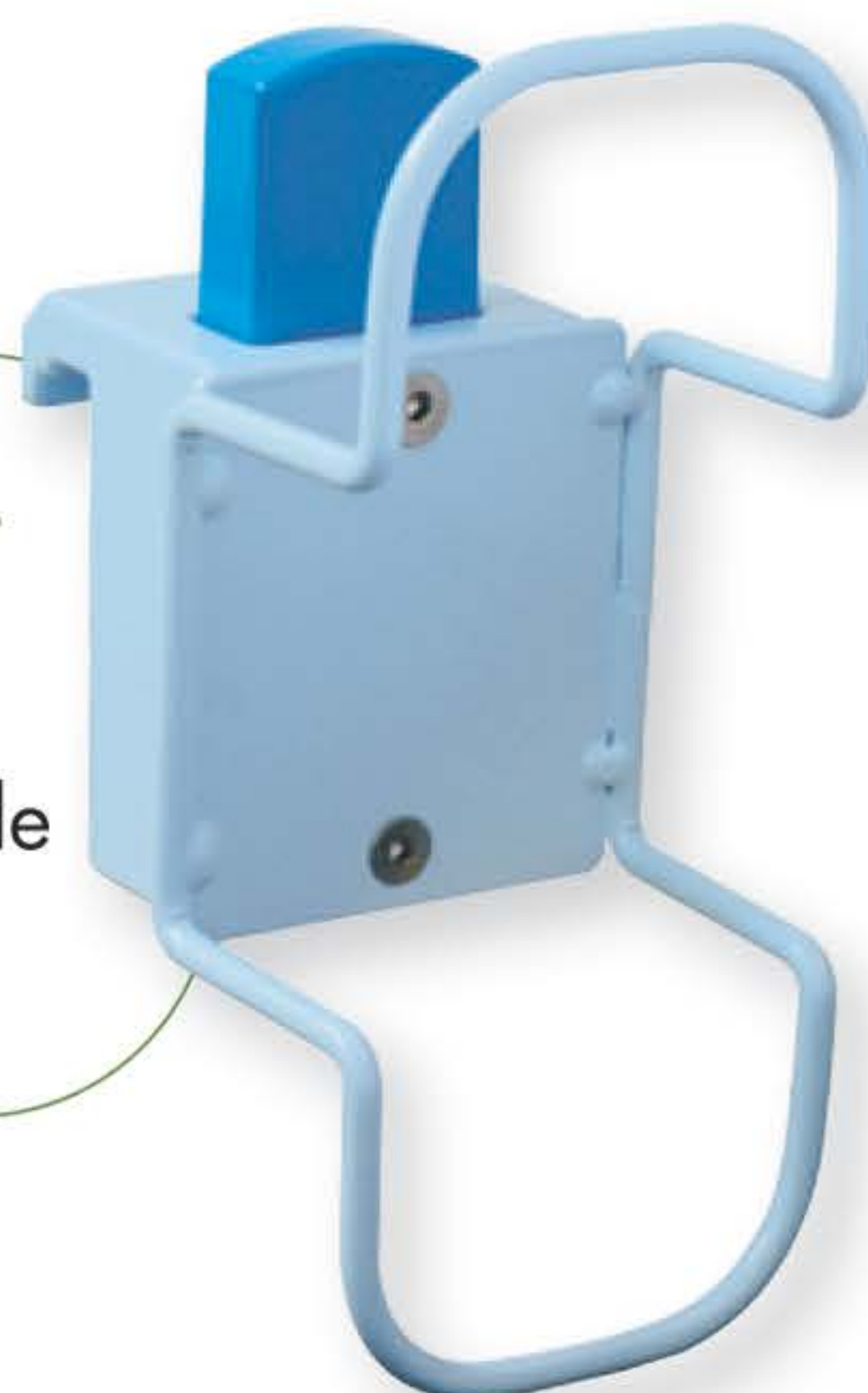

15658



15659



15660



- Attache universelle avec crochet
- *Universal clamp with hook*



17710



- Support porte blouse, attache universelle
- *White-coat holder with universal clamp*

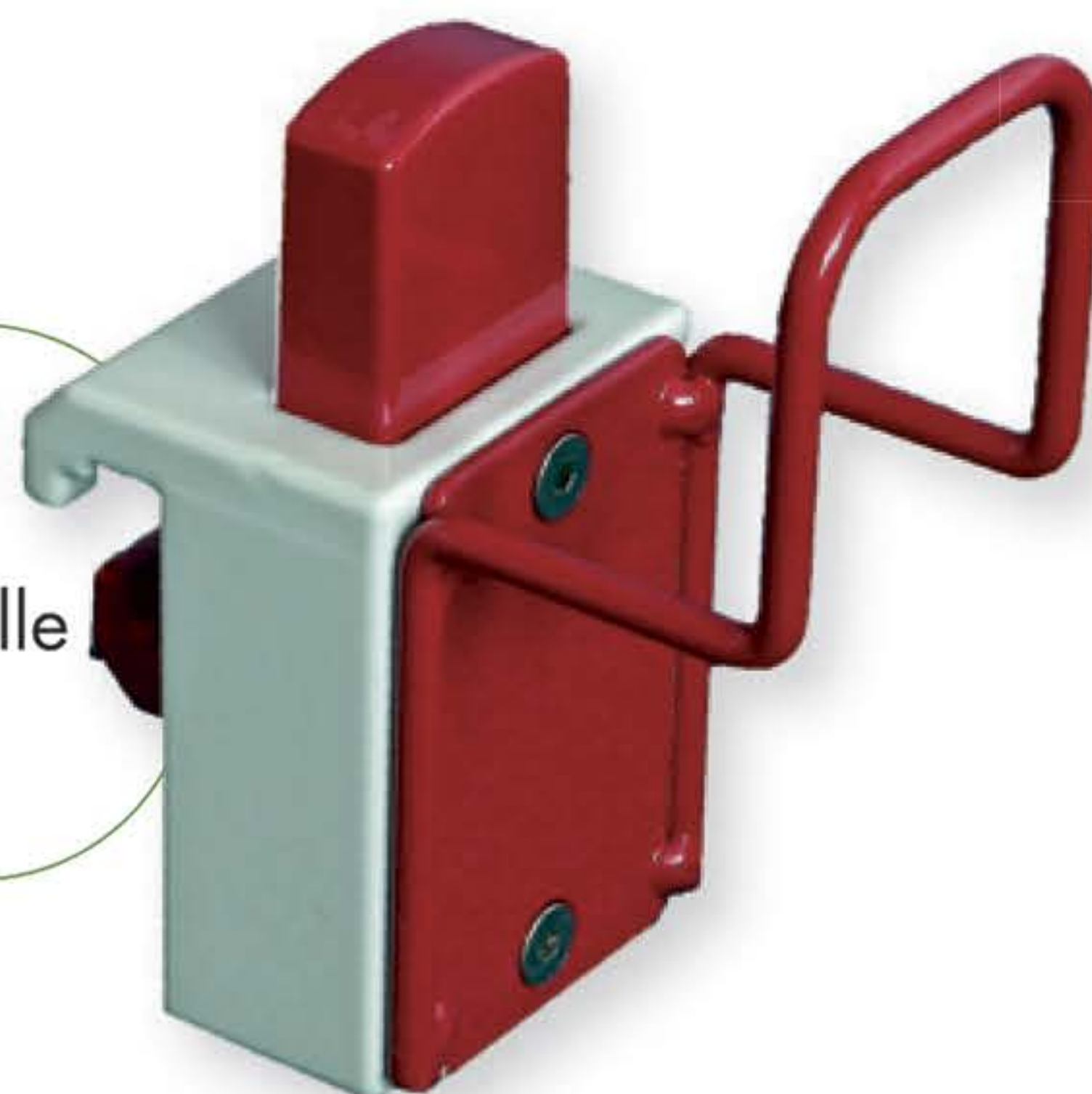



# CROCHETS SUPPORT TUBULURES

TUBE HOLDERS

**Crochets support tubulures, acier ressort rilsanisé**

**Tube holders, Rilsan® coated spring steel**

16028



16029



16030



16031



16032



16033



- Crochet support de tubulures pour rail épaisseur **10 mm**
- *Tube holder for direct mounting on 10 mm thick rail*

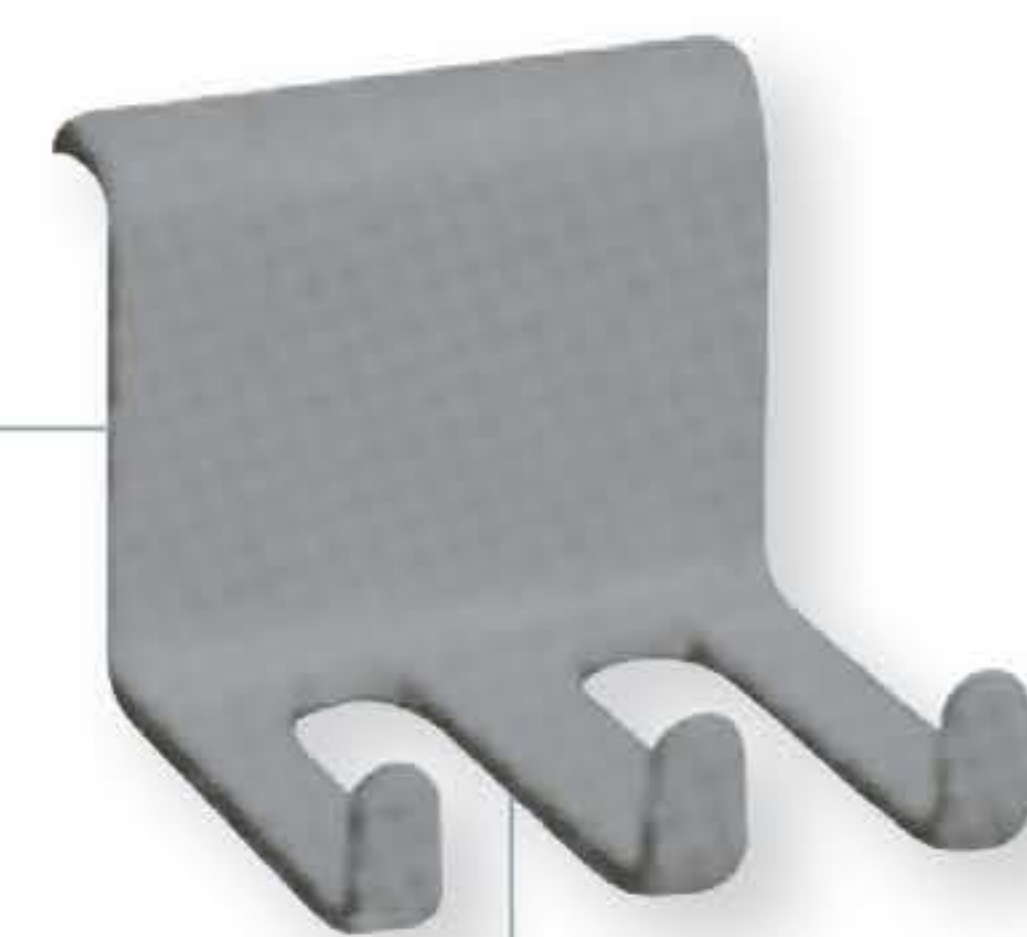
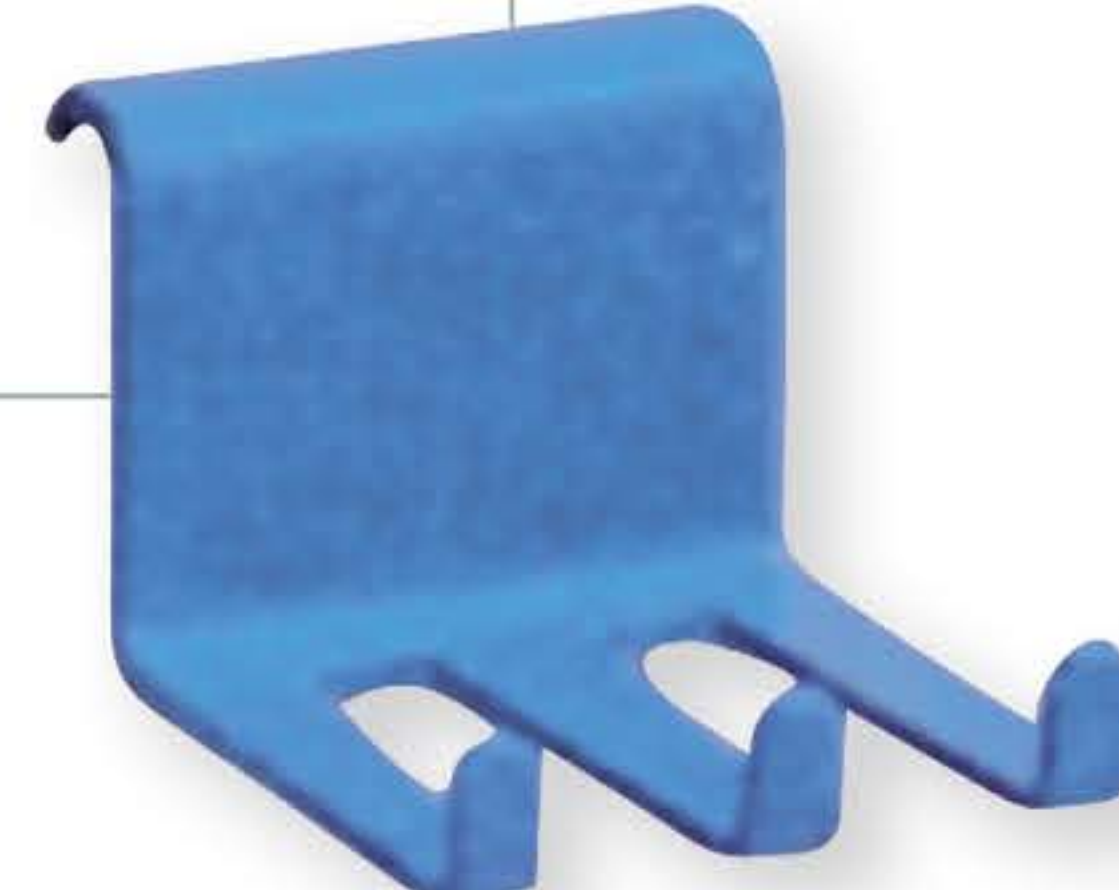
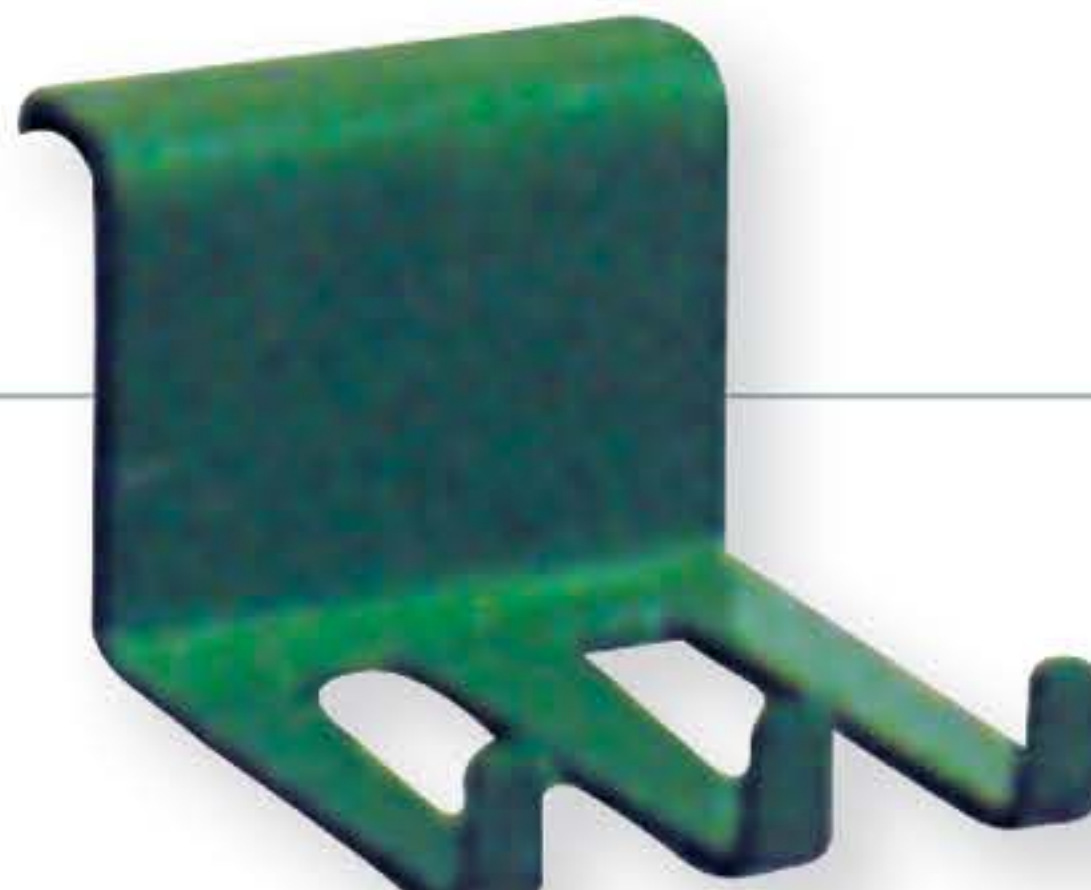
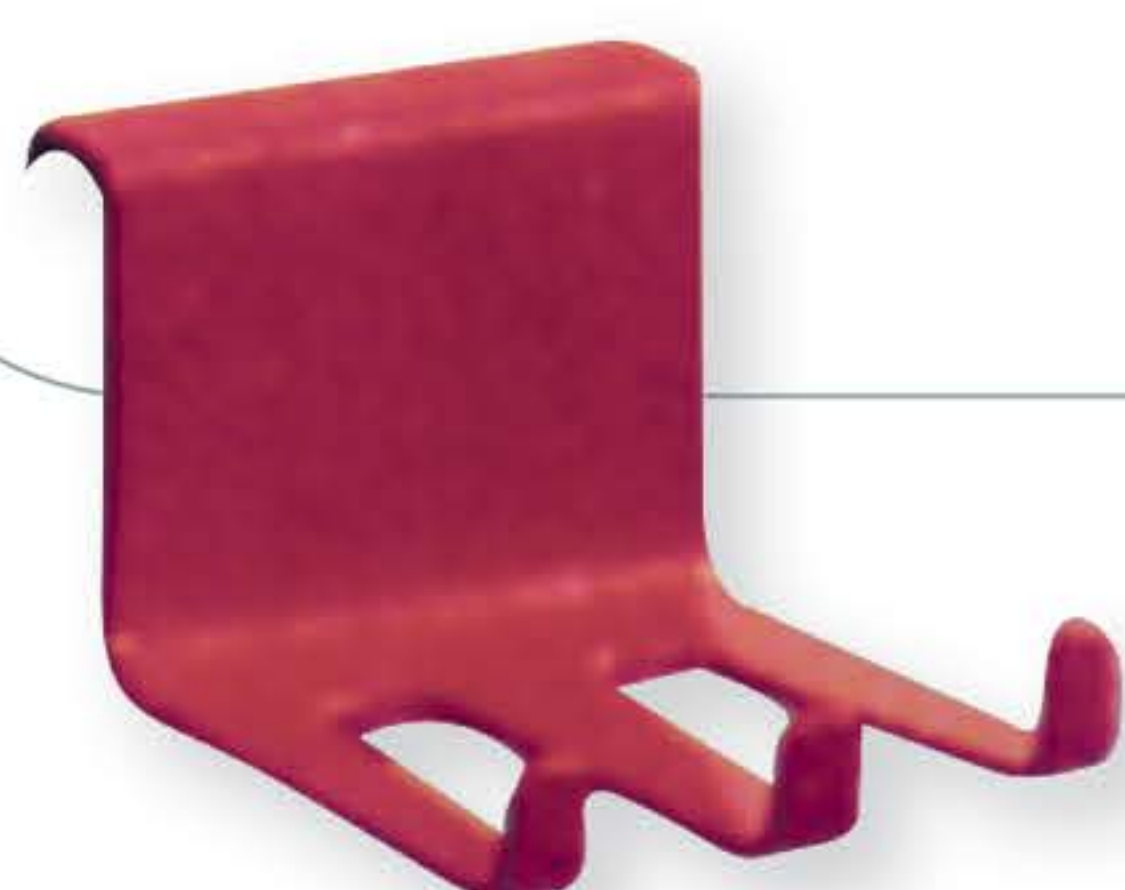



## Porte-documents pour accrochage direct au rail ou au lit, aluminium rilsané

*Notes holders for direct rail mounting or bed mounting, Rilsan® coated aluminium*

### Accrochage direct au rail / Direct rail mounting



15789 ●

15790 ●

- Porte-documents 300 x 210 mm
- Notes holder 300 x 210 mm

15793 ●

- Porte-documents 450 x 330 mm
- Notes holder 450 x 330 mm



### Accrochage mural / Direct wall mounting



18020 ●

- Porte-documents mural 490 x 390 mm
- Wall notes holder, 490 x 390 mm

### Accrochage direct au lit / Direct bed mounting

15811 ●

- Porte-documents 450 x 310 mm
- Notes holder 450 x 310 mm



15813 ●

- Porte-documents 450 x 310 mm  
1 attache centrale large
- Notes holder 450 x 310 mm  
1 large central hook





# PANIERIS DE STOCKAGE

**Paniers en acier rilsané pour accrochage direct au rail**

***Rilsan® coated steel storage baskets for direct rail mounting***

15843



15844



15845



- Panier 270 x 100 x 110 mm
- Basket 270 x 100 x 110 mm



15848



15849



15850



- Panier 295 x 170 x 120 mm
- Basket 295 x 170 x 120 mm

15853



15854



15855



- Panier 400 x 200 x 150 mm
- Basket 400 x 200 x 150 mm





# CONTENEURS DE SONDÉS

Conteneurs de sondes en acier rilsanisé pour accrochage direct au rail

**Catheter baskets, Rilsan® coated steel, for direct rail mounting**

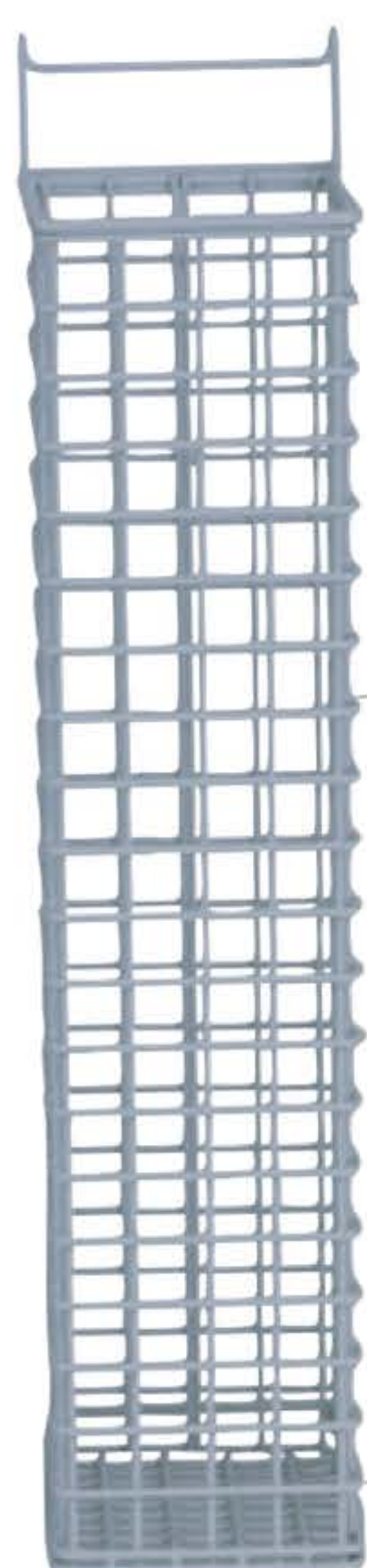

15857 | 15858 | 15859

- Conteneur de sondes, 1 case, 90 x 90 x 400 mm
- Catheter basket, 1 box, 90 x 90 x 400 mm

15867 | 19582 | 19583

- Conteneur de sondes, 1 case, 90 x 90 x 600 mm
- Catheter basket, 1 box, 90 x 90 x 600 mm

15863 | 15864 | 15865

- Conteneur de sondes pédiatrique, 1 case, 90 x 90 x 400 mm
- Paediatric catheter basket, 1 box, 90 x 90 x 400 mm

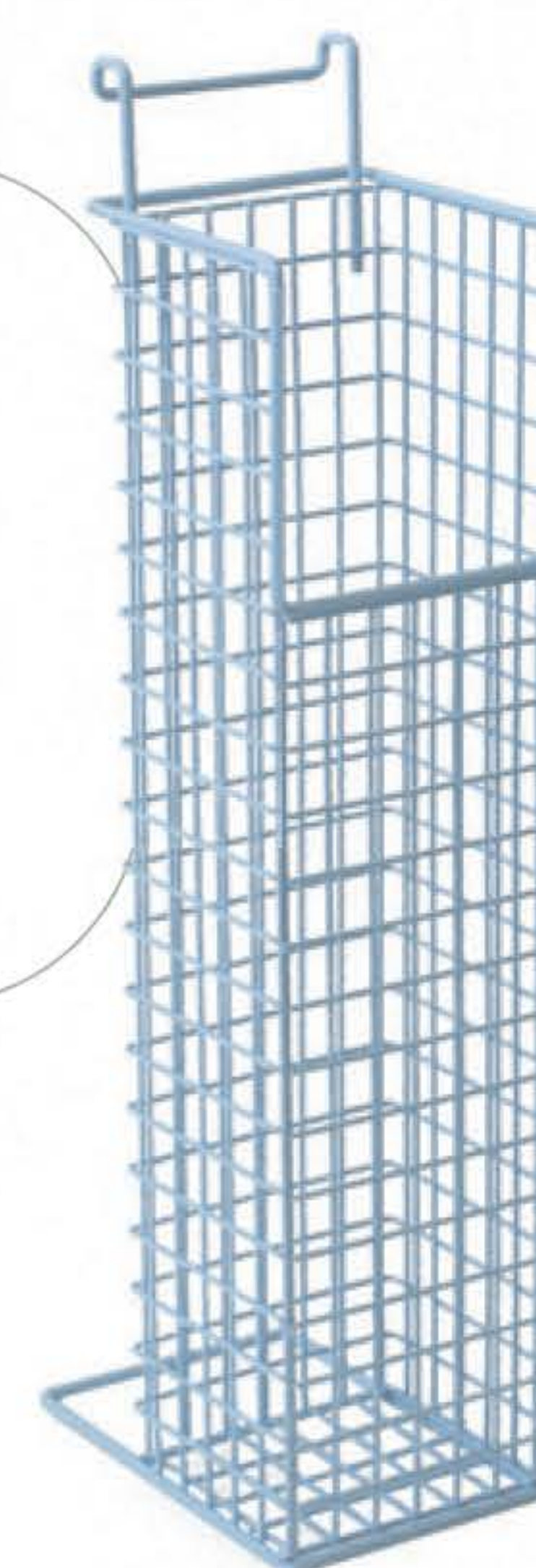

15875 | 15876 | 17135

- Conteneur de sondes, 2 cases, 200 x 90 x 600 mm,
- Catheter basket, 2 boxes, 200 x 90 x 600 mm

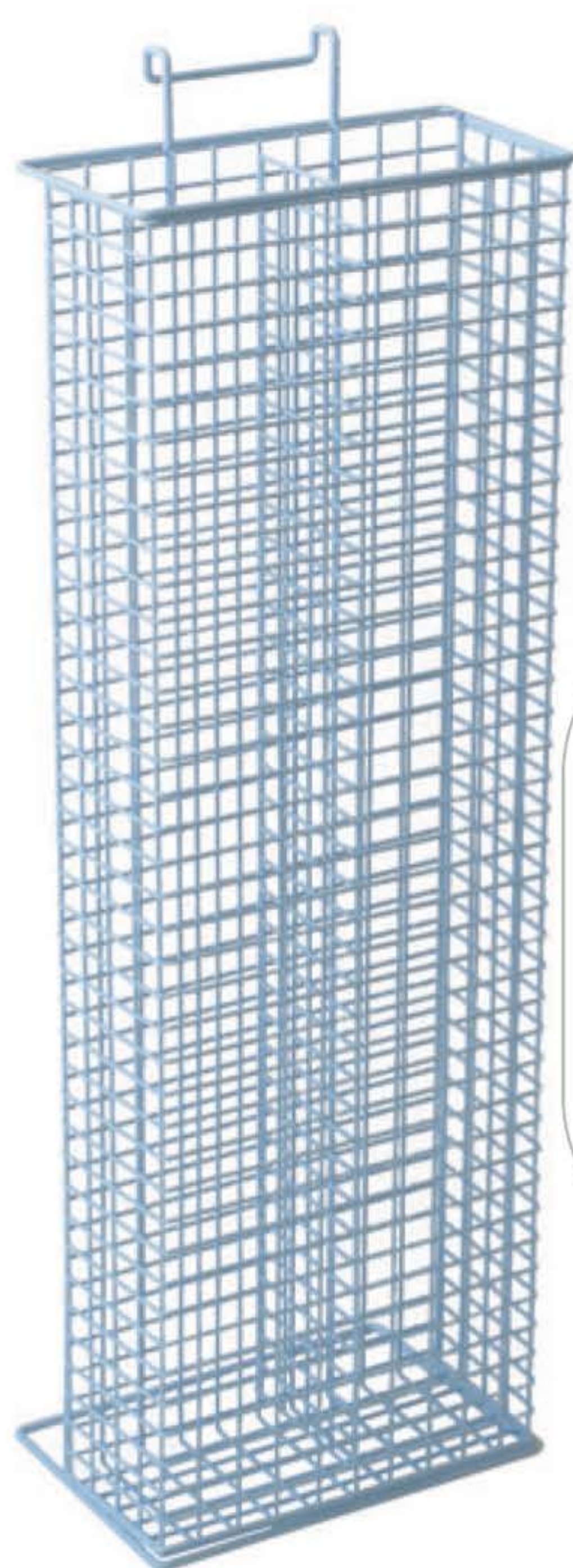

15869 | 15870 | 15871

- Conteneur de sondes, 2 cases, 200 x 90 x 400 mm
- Catheter basket, 2 boxes, 200 x 90 x 400 mm

15878 | 15879 | 15880

- Conteneur de sondes, 3 cases, 200 x 90 x 400 mm
- Catheter basket, 3 boxes, 200 x 90 x 400 mm

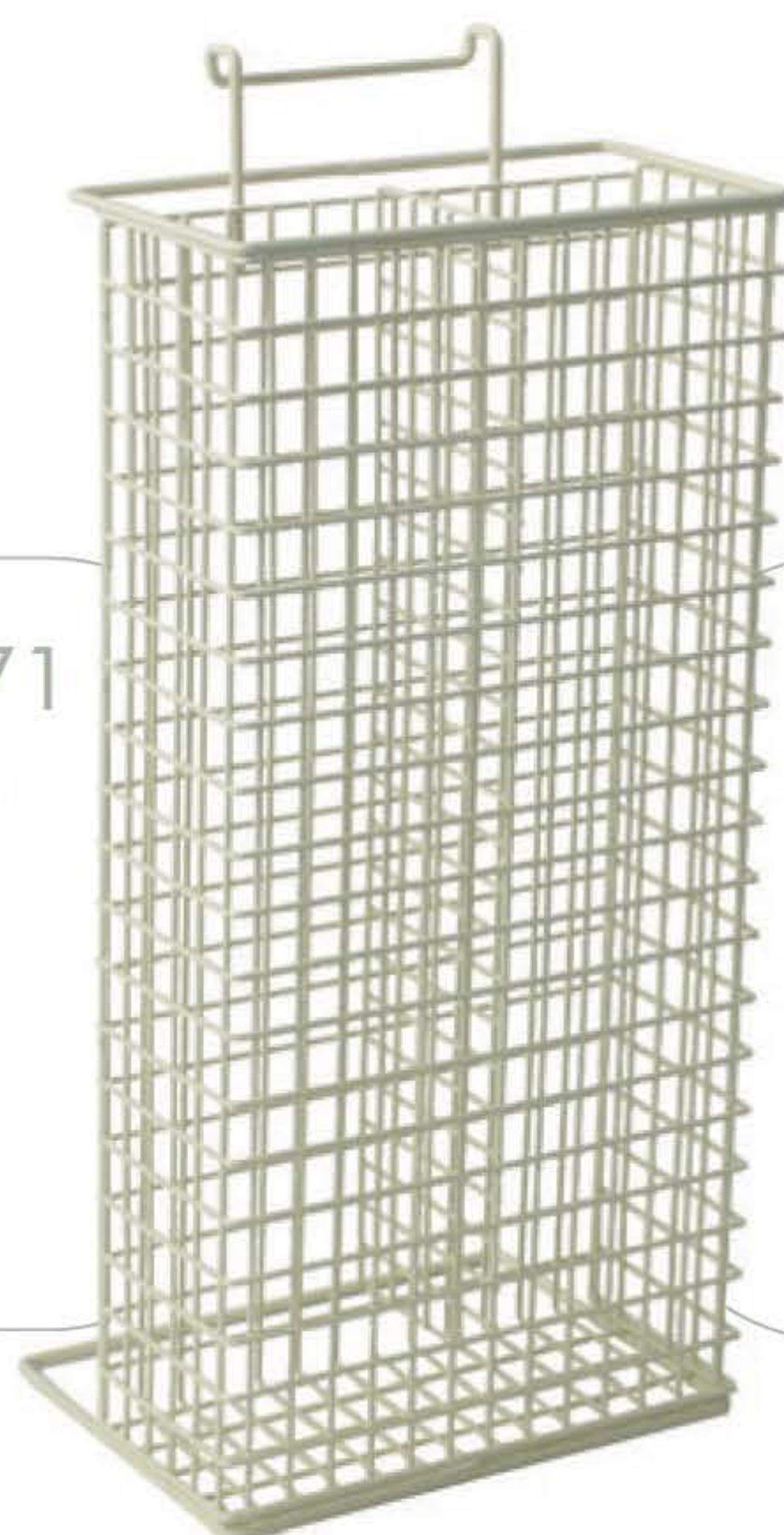



# PANIERES POUR BOCAUX

BASKETS FOR JARS  
AND BOTTLES

**Paniers en acier rilsanisé pour accrochage direct au rail**

**Baskets, Rilsan® coated steel, for direct rail mounting**

15565



15566



17304



- Panier pour flacon 500cc, Ø 90 mm
- Basket for 500cc bottle, Ø 90 mm



15568



15569



15570



- Panier pour flacon 1000cc, Ø 95 mm
- Basket for 1000cc bottle, Ø 95 mm

15550



15551



17687



- Panier pour bocal ABBOTT, Ø 100 mm, H 250 mm
- Basket for ABBOTT bottle, Ø 100 mm, H 250 mm



15572



17319



- Panier pour bocal aspiration, Ø 110 mm
- Basket for suction jar, Ø 110 mm

17816



17817



17818



- Panier pour bocal aspiration 2 L conique, Ø 152 mm, H 145 mm
- Basket for 2L cone-shaped suction jar, upper Ø 152 mm H 145 mm





# PANIERES POUR BOCAUX

BASKETS FOR JARS  
AND BOTTLES

## Paniers en acier rilsanisé pour accrochage direct au rail

Baskets, Rilsan® coated steel, for direct rail mounting



15546



15547



15548



- Panier pour bocal, Ø 136 mm
- Basket for jar, Ø 136 mm

17536



17537



17538



- Panier pour bocal 900 ml, Ø 103 mm, H 130 mm
- Basket for 900 ml bottle, Ø 103 mm H 130 mm

15553



15554



15555



- Panier pour flacon, 100 x 100 x 155 mm
- Basket for bottle, 100 x 100 x 155 mm

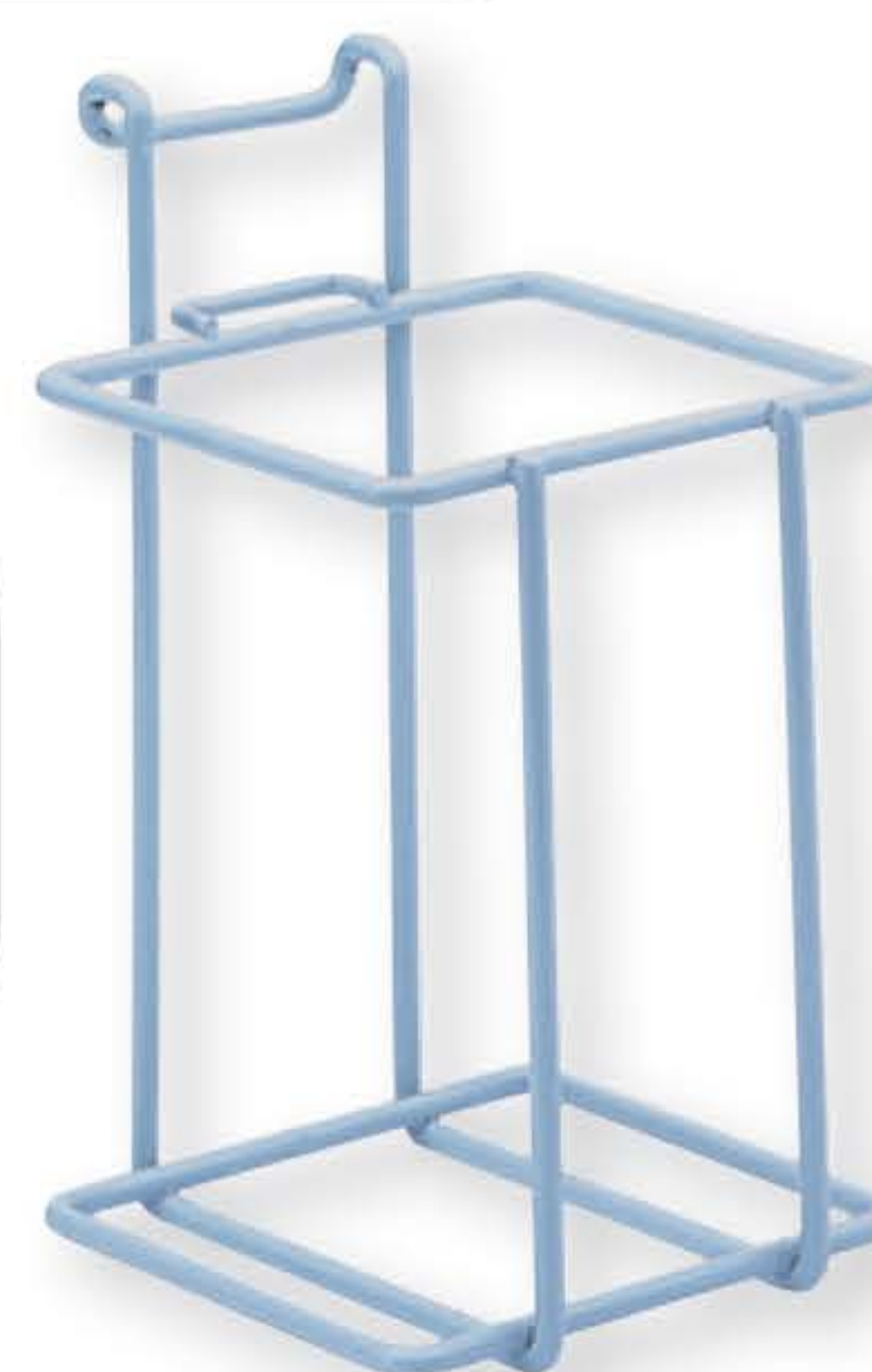

15557



15558



15559



- Panier pour flacon, 80 x 80 x 80 mm
- Basket for bottle, 80 x 80 x 80 mm



15561



15562



15563



- Panier pour flacon 500cc, 88 x 88 x 90 mm
- Basket for 500cc bottle, 88 x 88 x 90 mm





# TABLETTES ET CONSOLES

## SHELVES AND CONSOLE TABLES

### Tablettes en acier rilsanisé avec attaches universelles *Shelves, Rilsan® coated steel, with universal clamps*

15796



15797



15798



- Tablette porte-accessoires, 350 x 250 mm, charge maxi 10 kg
- Shelf for small accessories, 350 x 250 mm, maximum load 10 kg



17850



17851



17852



- Tablette acier rilsanisé 300 x 300 mm, bords 45°, charge maxi 10 kg
- Shelf, 300 x 300 mm, 45° edges, maximum load 10 kg

15800



15801



15802



- Tablette, 300 x 300 mm, charge maxi 13 kg
- Shelf, 300 x 300 mm, maximum load 13 kg

15804



15805



15806



- Tablette, 350 x 300 mm, charge maxi 13 kg
- Shelf, 350 x 300 mm, maximum load 13 kg



15807



15808



15809



- Tablette **rabattable**, 350 x 300 mm, charge maxi 10 kg
- Folding shelf, 350 x 300 mm, maximum load 10 kg





## Consoles en acier rilsanisé avec attaches universelles Console tables, Rilsan® coated steel, with universal clamps

### Équerres renforcées / Reinforced support brackets

16122



16123



16124



- Console, 500 x 400 mm, charge maxi 35 kg
- Console table, 500 x 400 mm, maximum load 35 kg

16132



16133



16134



- Console, 650 x 425 mm, charge maxi 35 kg
- Console table, 650 x 425 mm, maximum load 35 kg



### Équerres standard / Standard support brackets

16125



16126



16127



- Console, 500 x 400 mm, charge maxi 35 kg
- Console table, 500 x 400 mm, maximum load 35 kg



16135



16136



16137



- Console, 650 x 425 mm, charge maxi 35 kg
- Console table, 650 x 425 mm, maximum load 35 kg





### Consoles en acier rilsané avec attaches universelles

### Console tables, Rilsan® coated steel, with universal clamps

16119



16120



16121



- Console, 500 x 400 mm, charge maxi 35 kg, équerres standard, 1 tiroir
- Console table, 500 x 400 mm, maximum load 35 kg, standard support brackets, 1 drawer



16081



16082



16083



- Console, 650 x 425 mm, charge maxi 35 kg, équerres standard, 1 tiroir
- Console table, 650 x 425 mm, maximum load 35 kg, standard support brackets, 1 drawer

16078



16079



16080



- Console, 650 x 425 mm, charge maxi 35 kg, équerres renforcées, 1 tiroir
- Console table, 650 x 425 mm, maximum load 35 kg, reinforced support brackets, 1 drawer





## Attention au porte-à-faux du rail !

Mind the rail cantilever!

Le porte-à-faux (distance du mur à la face avant du rail)  
pour notre rail GAUCHARD MEDICAL®/MEDIRAIL® est de **50 mm**.

The cantilever (the space between the wall and the front face of the rail)  
for our rail measures **50 mm**.

> **Tablettes rabattables**

> Folding shelves

> **Consoles avec équerres renforcées**

> Console tables with reinforced support brackets

> **Consoles pivotantes**

> Rotating console tables

➔ p.20, 21, 22

➔ **Pour un porte-à-faux inférieur à 50 mm :**

For a cantilever under 50 mm:

Pour les tablettes rabattables et consoles pivotantes  
For folding shelves and rotating console tables

> **Prévoir 2 entretoises 45 x 60 x 10 mm ou 45 x 60 x 15 mm**

> Provide two 45 x 60 x 10 mm or 45 x 60 x 15 mm spacers

Pour les consoles avec équerres renforcées  
For console tables with reinforced support brackets

> **Prévoir 4 entretoises Ø 18 mm**

> Provide four Ø 18 mm spacers

➔ **Pour un porte-à-faux supérieur à 50 mm :**

For a cantilever over 50 mm:

De 60 mm à 70 mm  
From 60 mm to 70 mm

> **Prévoir 2 vis TCHC 8/16 avec butée**

> Provide two 8/16 hollow hexagonal cylindrical head screws with stop

> **Prévoir 2 vérins réglables**

> Provide two adjustable jacks

A prévoir également pour l'installation sur le système de rail mobile.

To provide for mounting on the adjustable rail system as well.

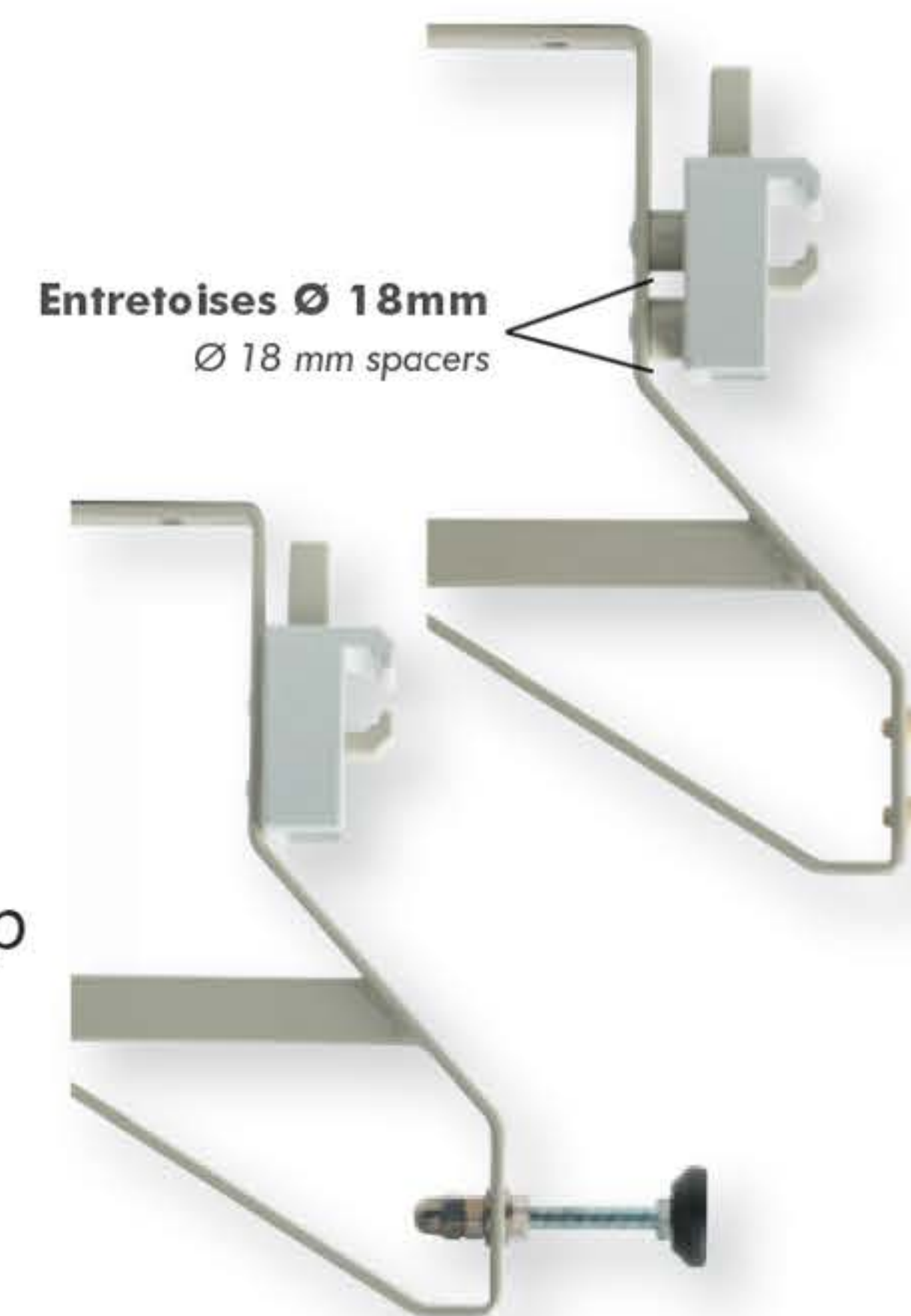

Référence Reference	Coloris disponibles Available colours	Désignation Description
<b>17187</b>		Vérin réglable - 2 verins par tablette ou console Adjustable jack (2 jacks per shelf or console table)
<b>17300</b>		Vis TCHC 8/16 avec butée - 2 par tablette 8/16 hollow hexagonal cylindrical head screw with stop (2 screws per shelf)
<b>17284</b>	gris / grey	Entretoise : Ø18 mm aluminium rilsané - 4 entretoises par console Ø18 mm Rilsan® coated aluminium spacer (4 spacers per console table)
<b>17285</b>	bleu / blue	
<b>17286</b>	grès / light brown	
<b>17278</b>	gris / grey	
<b>17279</b>	bleu / blue	Entretoise larg. 45 / h. 60 / ép. 10 mm - 2 entretoises par console 45 x 60 x 10 mm spacer (2 spacers per console table)
<b>17280</b>	grès / light brown	
<b>17281</b>	gris / grey	Entretoise larg. 45 / h. 60 / ép. 15 mm - 2 entretoises par console 45 x 60 x 15 mm spacer (2 spacers per console table)
<b>17282</b>	bleu / blue	
<b>17283</b>	grès / light brown	





# BLOCS CHEVET MODULABLES

ADJUSTABLE  
DRAWER UNITS

## Blocs chevet en acier rilsanisé avec attaches universelles

*Drawer units, Rilsan® coated steel, with universal clamps*



16160



16161



- Bloc chevet, 1 tiroir, 465 x 380 x 140 mm, charge maxi 32,5 kg
- *Drawer unit, 1 drawer, 465 x 380 x 140 mm, maximum load 32.5 kg*



16163



16164



- Bloc chevet, 2 tiroirs, 465 x 380 x 280 mm, charge maxi 25 kg
- *Drawer unit, 2 drawers, 465 x 380 x 280 mm, maximum load 25 kg*





### Porte-sondes adultes avec attaches universelles

Adult catheter holders, Rilsan® coated steel, with universal clamps



#### 16008

- Tube verre PYREX, Ø 60 mm, H 400 mm
- Pyrex glass tube, Ø 60 mm, H 400 mm

#### 15998



- Support 1 tube, seul
- Holder for 1 tube, only

#### 15999



- Support 1 tube, seul
- Holder for 1 tube, only

#### 16000



- Support 1 tube, seul
- Holder for 1 tube, only

#### 16009



- Support 2 tubes, seul
- Holder for 2 tubes, only

#### 16010



- Support 2 tubes, seul
- Holder for 2 tubes, only

#### 16011



- Support 2 tubes, seul
- Holder for 2 tubes, only

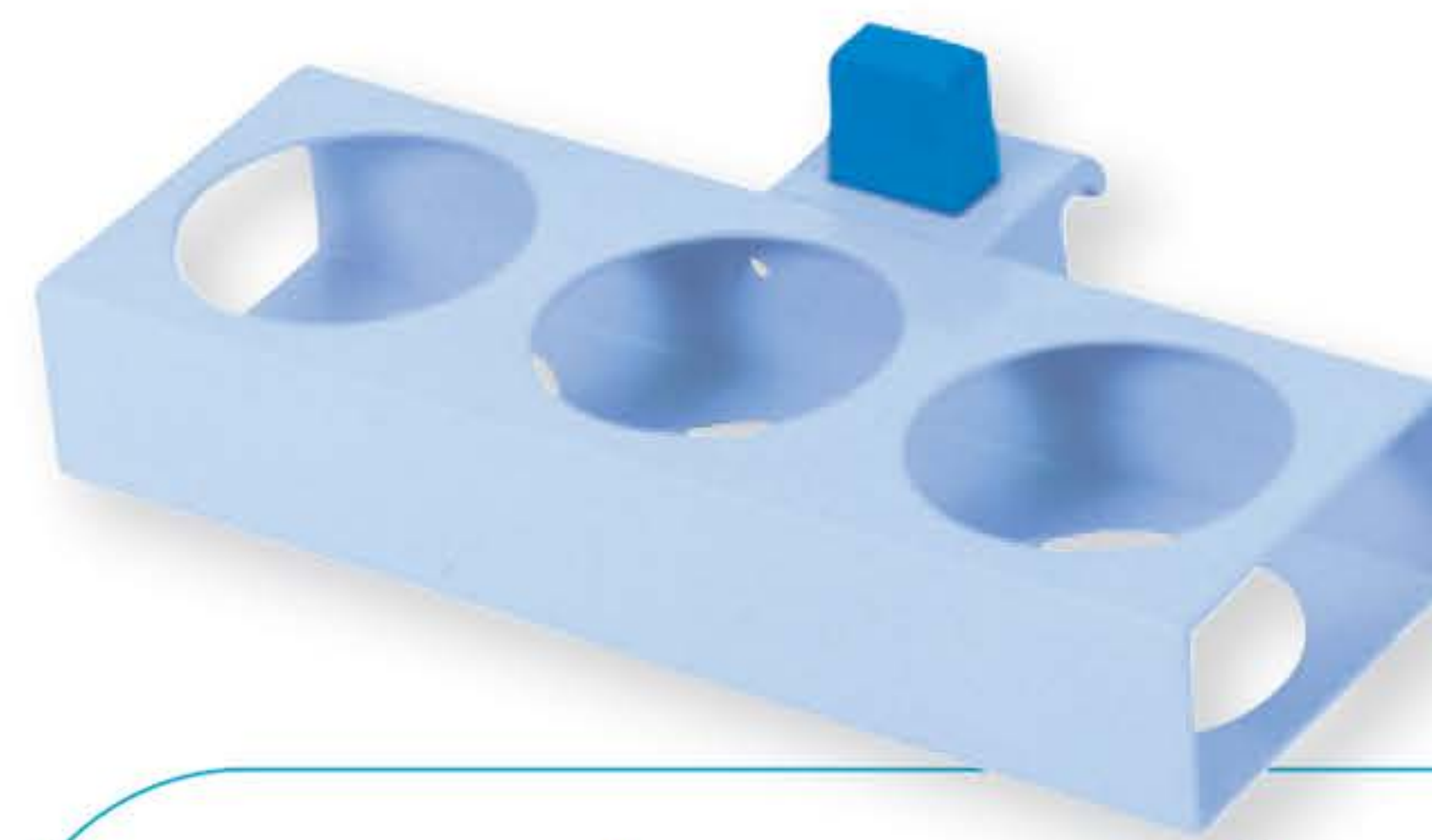

#### 11912

- Tube en polycarbonate, Ø 52 mm, H 400 mm
- Polycarbonate tube, Ø 52 mm, H 400 mm

#### 11910

- Tube en polycarbonate, Ø 52 mm, H 500 mm
- Polycarbonate tube, Ø 52 mm diameter, H 500 mm



#### 16034



- Support 3 tubes, seul
- Holder for 3 tubes, only

#### 16035



- Support 3 tubes, seul
- Holder for 3 tubes, only

#### 16036



- Support 3 tubes, seul
- Holder for 3 tubes, only

#### 16043



- Support 4 tubes, seul
- Holder for 4 tubes, only

#### 16044



- Support 4 tubes, seul
- Holder for 4 tubes, only

#### 16045



- Support 4 tubes, seul
- Holder for 4 tubes, only





### Porte-sondes pédiatriques avec attaches universelles

*Paediatric catheter holders, Rilsan® coated steel, with universal clamps*

15821



15822



15823



- Support 1 tube, seul
- Holder for 1 tube, only

15830



15831



15832



- Support 2 tubes, seul
- Holder for 2 tubes, only



15873

- Tube polypropylène, Ø 30 mm, H 100 mm
- Polypropylene tube, Ø 30 mm, H 100 mm

### Support boîte à gants en acier rilsanisé

*Rilsan® coated gloves box holder*

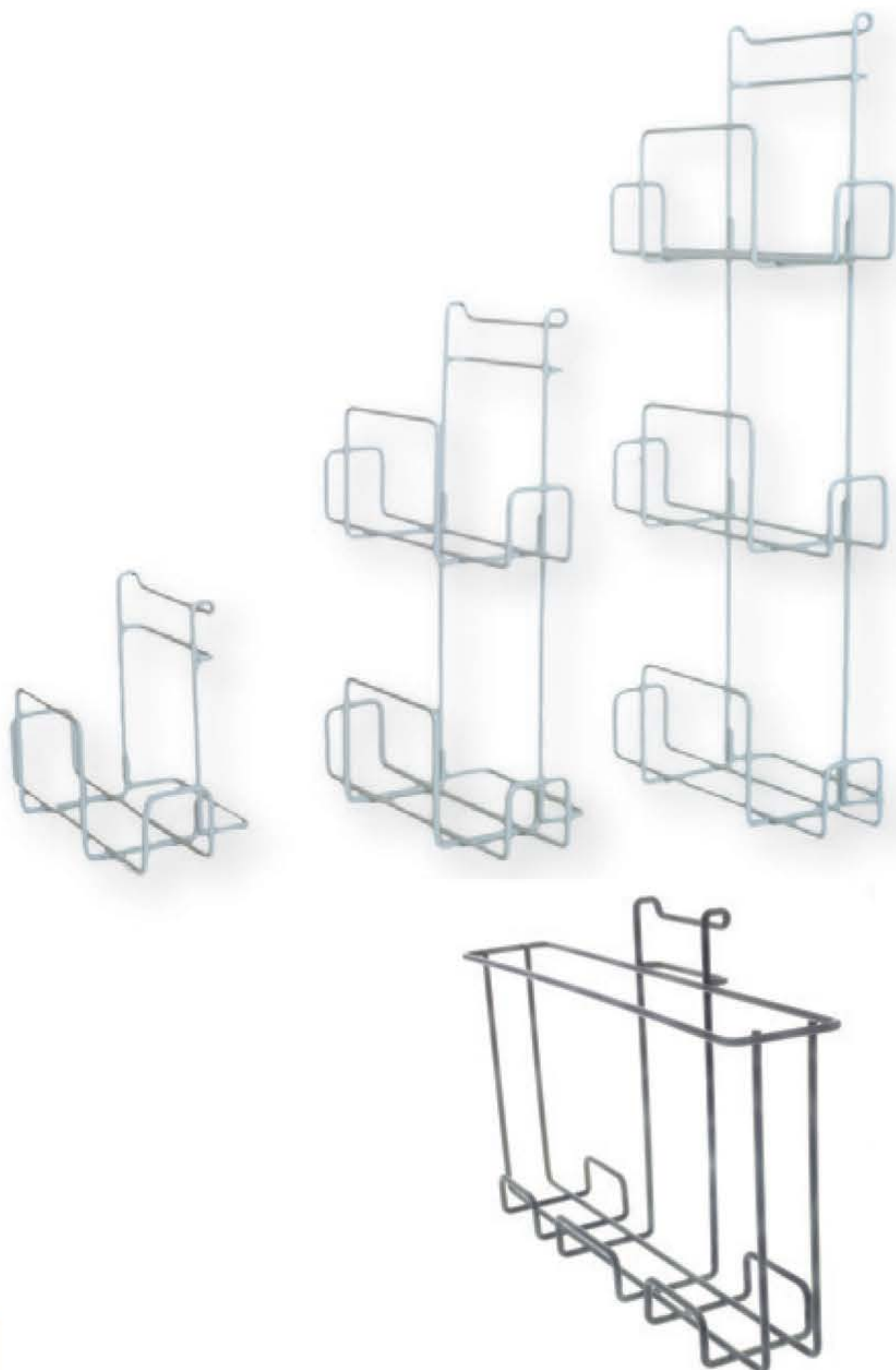

19730 ●

- Support vertical pour 1 boîte à gants
- Vertical holder for 1 gloves box

19733 ●

- Support vertical pour 2 boîtes à gants
- Vertical holder for 2 gloves boxes

18059 ●

- Support vertical pour 3 boîtes à gants
- Vertical holder for 3 gloves boxes

20052 ● 20053 ● 20205 ●

- Support horizontal pour 3 boîtes de 100 gants
- Horizontal holder for 3 boxes of 100 gloves

22007 ● 22008 ● 22009 ●

- Support horizontal pour 3 boîtes de 200 gants
- Horizontal holder for 3 boxes of 200 gloves





# PORTE-SACHETS D'EXAMEN PORTE-SAC A DECHETS

SPECIMEN BAG HOLDER  
RUBBISH BAG BASKETS

## Porte-sachets d'examen mural en acier rilsané

**Rilsan® coated steel specimen bag holder  
for direct wall mounting**

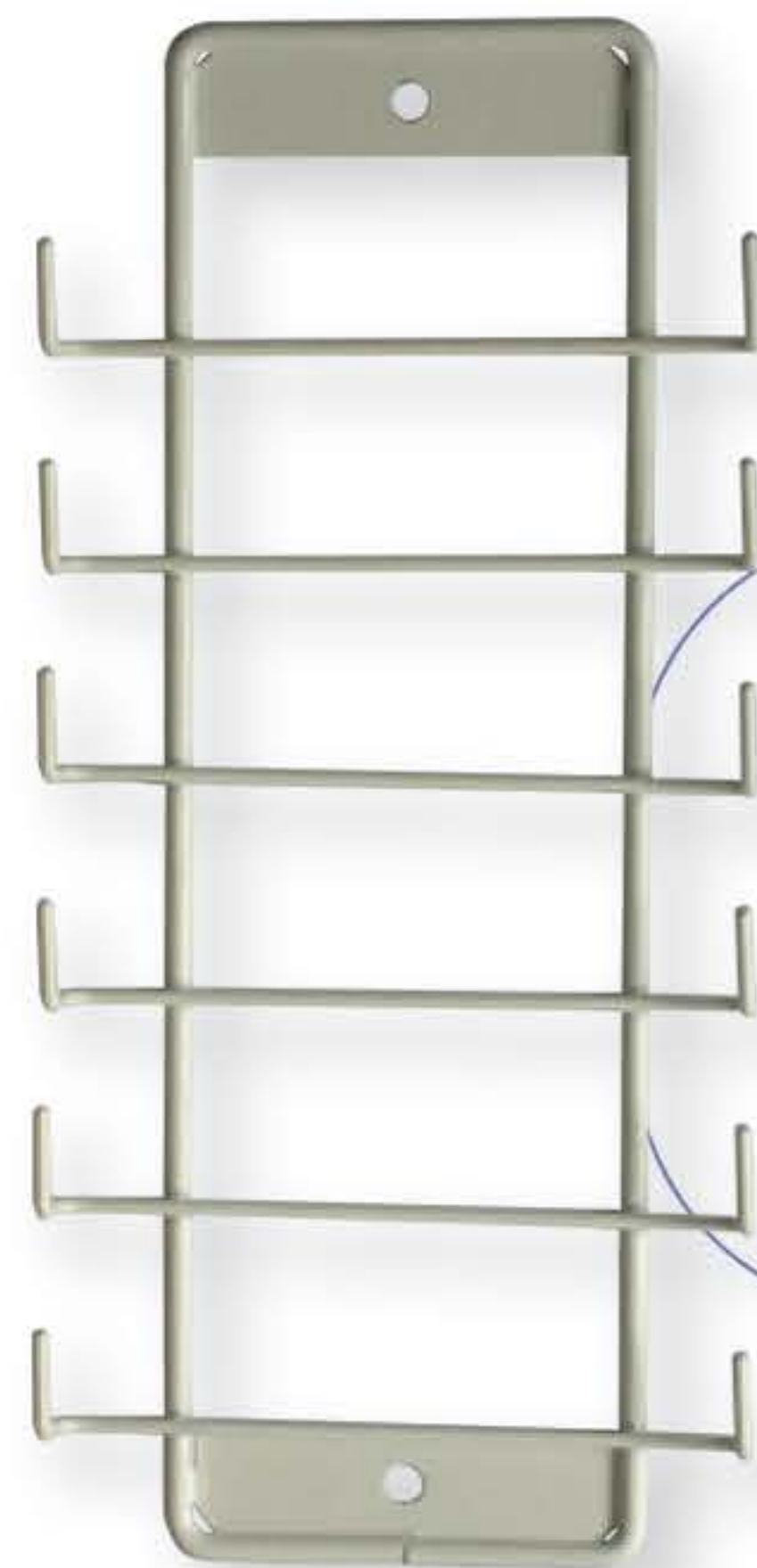

15574 ○

- Support mural pour 6 sachets "EXAMENS"
- Specimen bag holder for 6 bags, bags excluded

## Panier Porte-sac à déchets en acier rilsané

**Rilsan® coated steel rubbish bag baskets**

15835 ●

17333 ●

15834 ○

- Porte-sac à déchet 150 x 150 x 240 mm, accrochage direct au rail
- Rubbish bag basket, 150 x 150 x 240 mm, for direct rail mounting



15839 ●

17095 ●

15837 ●

- Porte-sac à déchet 260 x 150 x 250 mm, accrochage direct au rail
- Rubbish bag basket, 260 x 150 x 250 mm, for direct rail mounting





# PORTE-SAC POUBELLE

**Porte-sac poubelle avec attache universelle à glissière ou accrochage direct au rail, acier rilsanisé**

**Rubbish bag holders with universal clamp with mounting slot or direct rail mounting, Rilsan® coated steel**

Accrochage avec attache universelle à glissière

*Universal clamp with mounting slot*

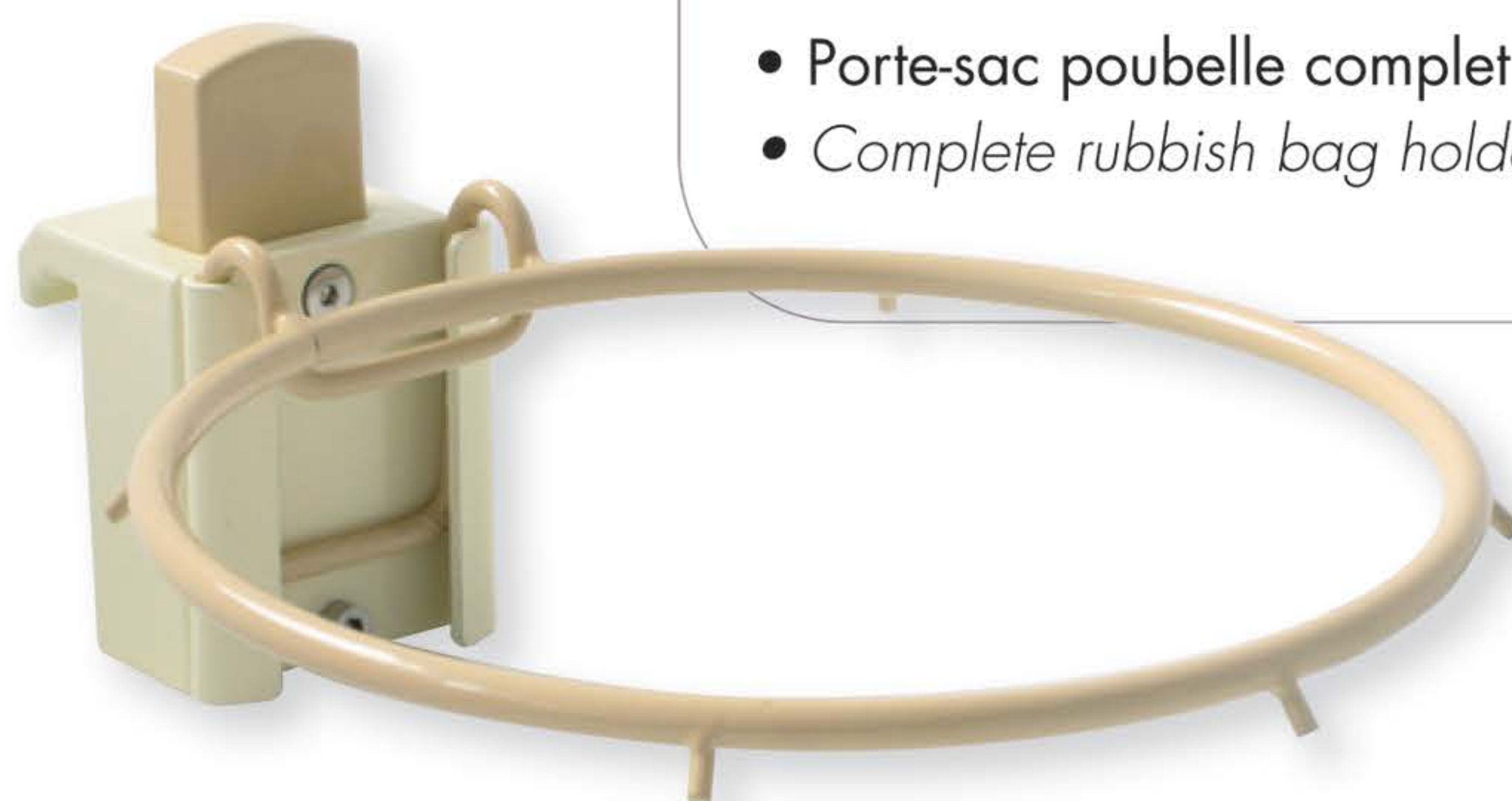

15910



15911



15912



- Porte-sac poubelle complet Ø 155 mm
- Complete rubbish bag holder, Ø 155 mm

Accrochage direct au rail

*Direct rail mounting*

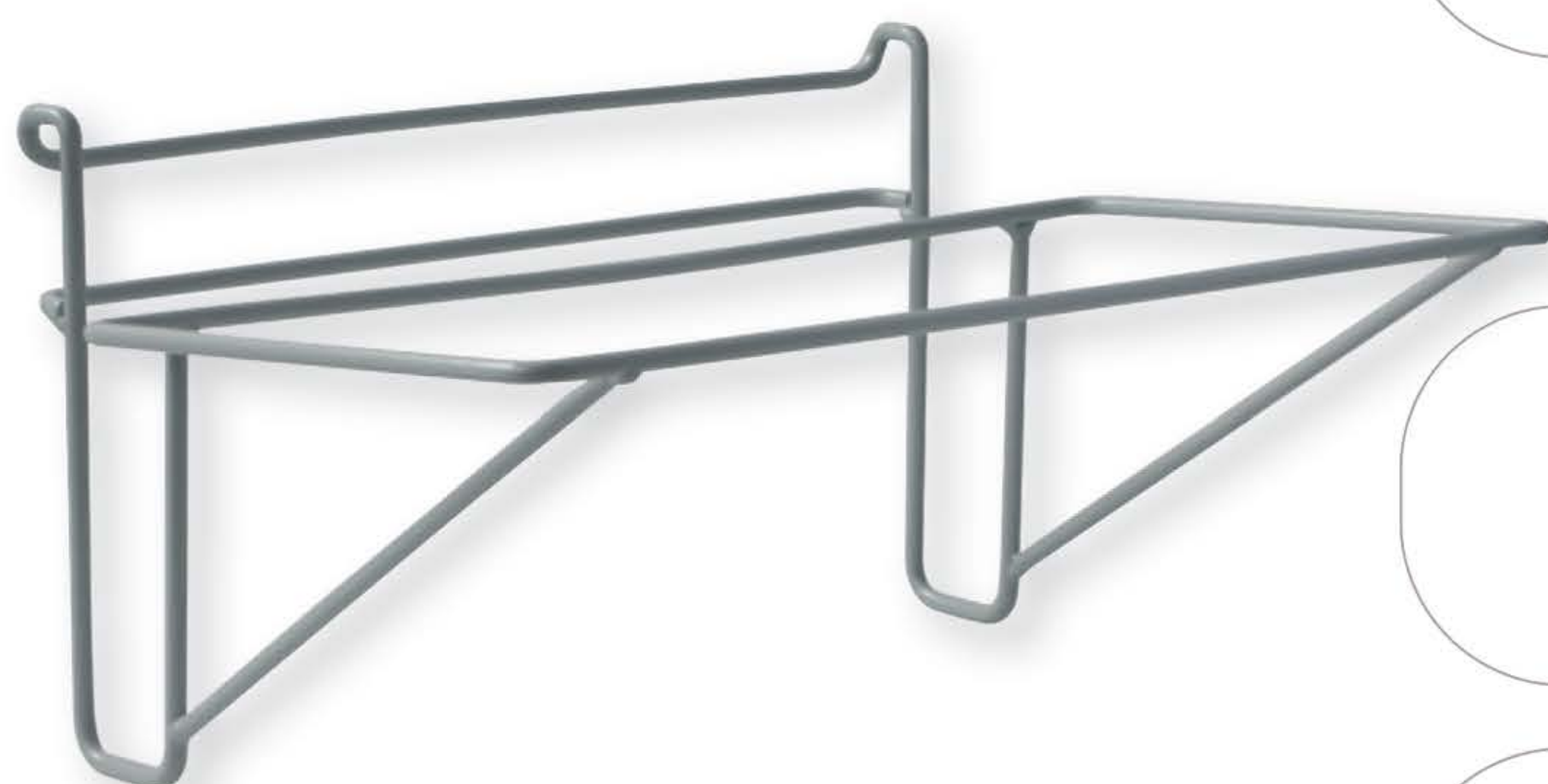

16932 ●

- Porte-sac poubelle complet 320 x 160 mm
- Complete rubbish bag holder, 320 x 160 mm

15913

- Sac poubelle 5L - lot de 50 sacs
- Rubbish bag 5L - Batch of 50 bags

15914

- Sac poubelle 10L - lot de 50 sacs
- Rubbish bag 10L - Batch of 50 bags





## Porte-sérum en acier rilsanisé Drip stands, Rilsan® coated steel



### 15893

- Tige inox porte-sérum, Ø16 mm, double courbure (1500 mm), 2 crochets POLYAMIDE, (sans support)
- *Stainless steel double bend drip stand, Ø 16 mm, H 1500 mm with 2 POLYAMIDE hooks (without bracket)*

### 15894

- Tige inox porte-sérum, Ø16 mm, double courbure (1200 mm), 2 crochets POLYAMIDE, (sans support)
- *Stainless steel double bend drip stand, Ø 16 mm, H 1200 mm with 2 POLYAMIDE hooks (without bracket)*

### 15895

- Tige inox porte-sérum, Ø16 mm, double courbure (1500 mm), 2 crochets INOX, (sans support)
- *Stainless steel double bend drip stand, Ø 16 mm, H 1500 mm with 2 STAINLESS STEEL hooks (without bracket)*

### 15896

- Tige inox porte-sérum, Ø16 mm, double courbure (1200 mm), 4 crochets INOX, (sans support)
- *Stainless steel double bend drip stand, Ø 16 mm, H 1200 mm with 4 STAINLESS STEEL hooks (without bracket)*

### 15900

- Tige inox porte-sérum, Ø16 mm, double courbure (1500 mm), 4 crochets INOX, (sans support)
- *Stainless steel double bend drip stand, Ø 16 mm, H 1500 mm with 4 STAINLESS STEEL hooks (without bracket)*

### 15897

- Tige inox porte-sérum, Ø16 mm, droite (1500 mm), 2 crochets POLYAMIDE, (sans support)
- *Stainless steel straight drip stand, Ø 16 mm, H 1500 mm with 2 POLYAMIDE hooks (without bracket)*

### 15898

- Tige inox porte-sérum, Ø16 mm, droite (1500 mm), 2 crochets INOX, (sans support)
- *Stainless steel straight drip stand, Ø 16 mm, H 1500 mm with 2 STAINLESS STEEL hooks (without bracket)*

### 15899

- Tige inox porte-sérum, Ø16 mm, droite (1500 mm), 4 crochets INOX, (sans support)
- *Stainless steel straight drip stand, Ø 16 mm, H 1500 mm with 4 STAINLESS STEEL hooks (without bracket)*



### 15888



### 15889



### 15890



- Support tige porte-sérum, Ø 16 mm, attache universelle haute résistance, avec vis de blocage
- Bracket for drip stand, Ø 16 mm and heavy duty universal rail clamp with locking screw





# POTENCES MURALES

## Potences murales en acier rilsanisé

### Wall arm hooks, Rilsan® coated steel



15970



15971



15972



- Potence murale, 1 bras articulé L 850 mm
- Wall arm hook, L 850 mm, 1 swivel arm

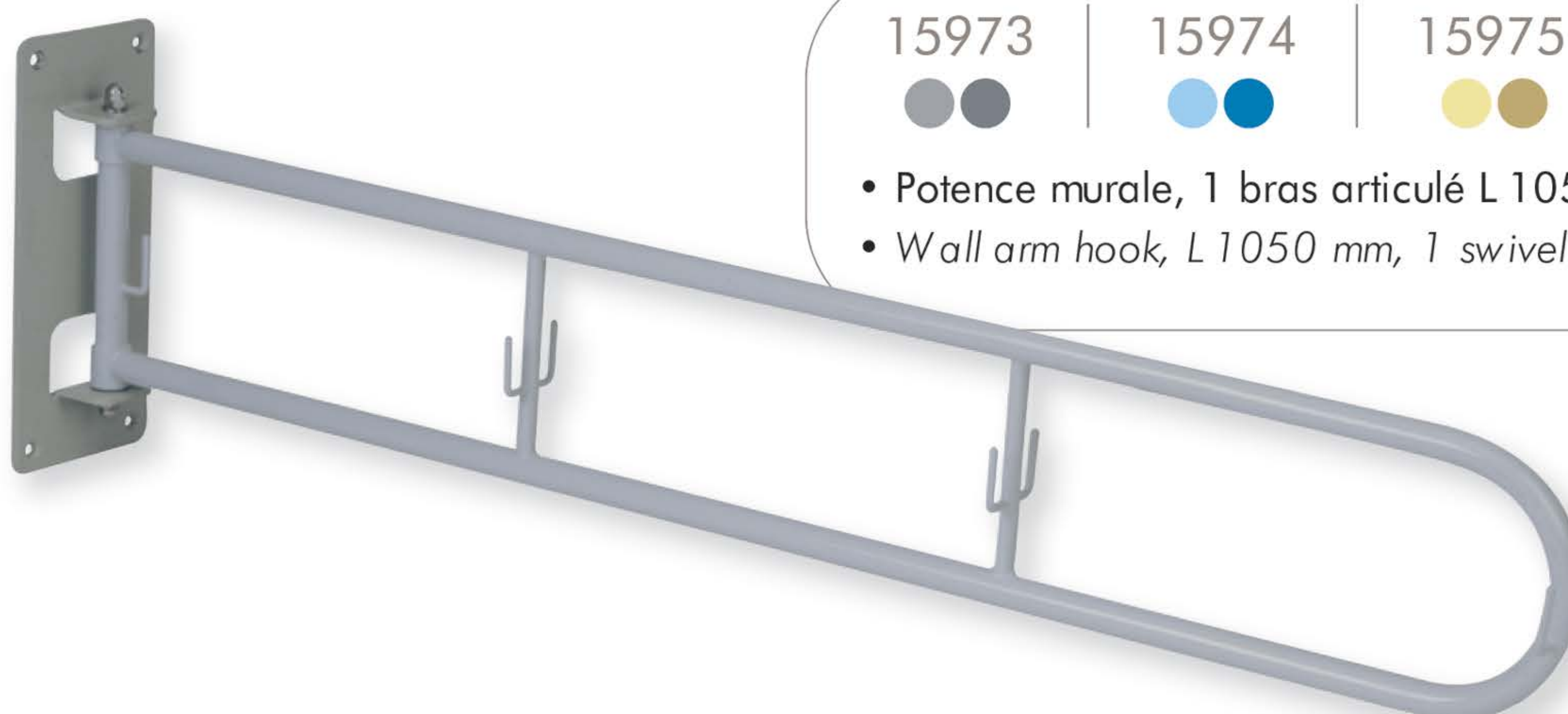

15973



15974



15975



- Potence murale, 1 bras articulé L 1050 mm
- Wall arm hook, L 1050 mm, 1 swivel arm

15976



15977



15978



- Potence murale, 2 bras articulés L 1800 mm
- Wall arm hook, L 1800 mm, 2 swivel arms

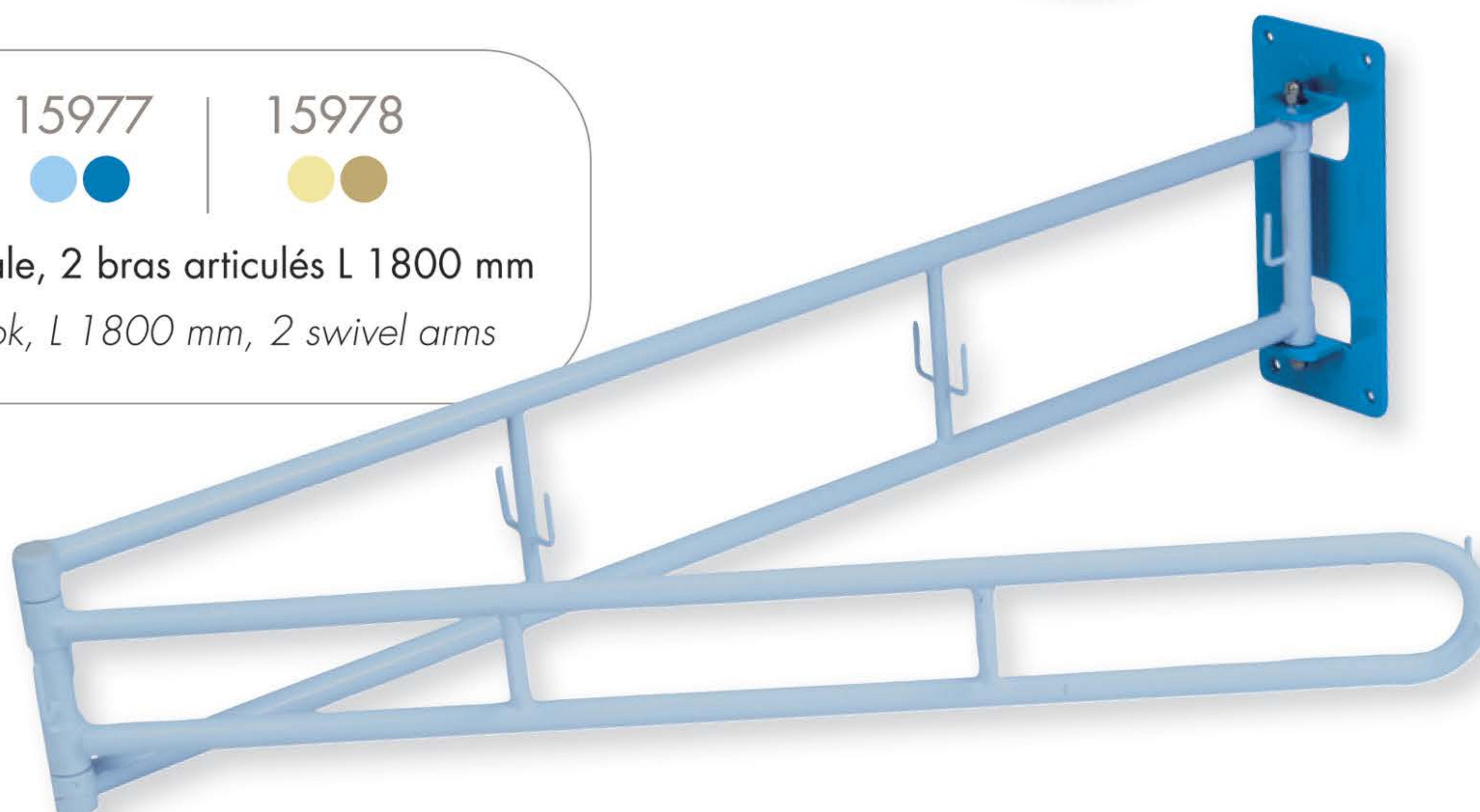

Chevilles, vis et cache-vis à commander séparément  
Anchors, screws and caps to be ordered separately





# BARRES DE SUPPORT POUR POUSSE-SERINGUES

Barres support  
Support poles

SUPPORT POLES FOR  
SYRINGE PUMPS

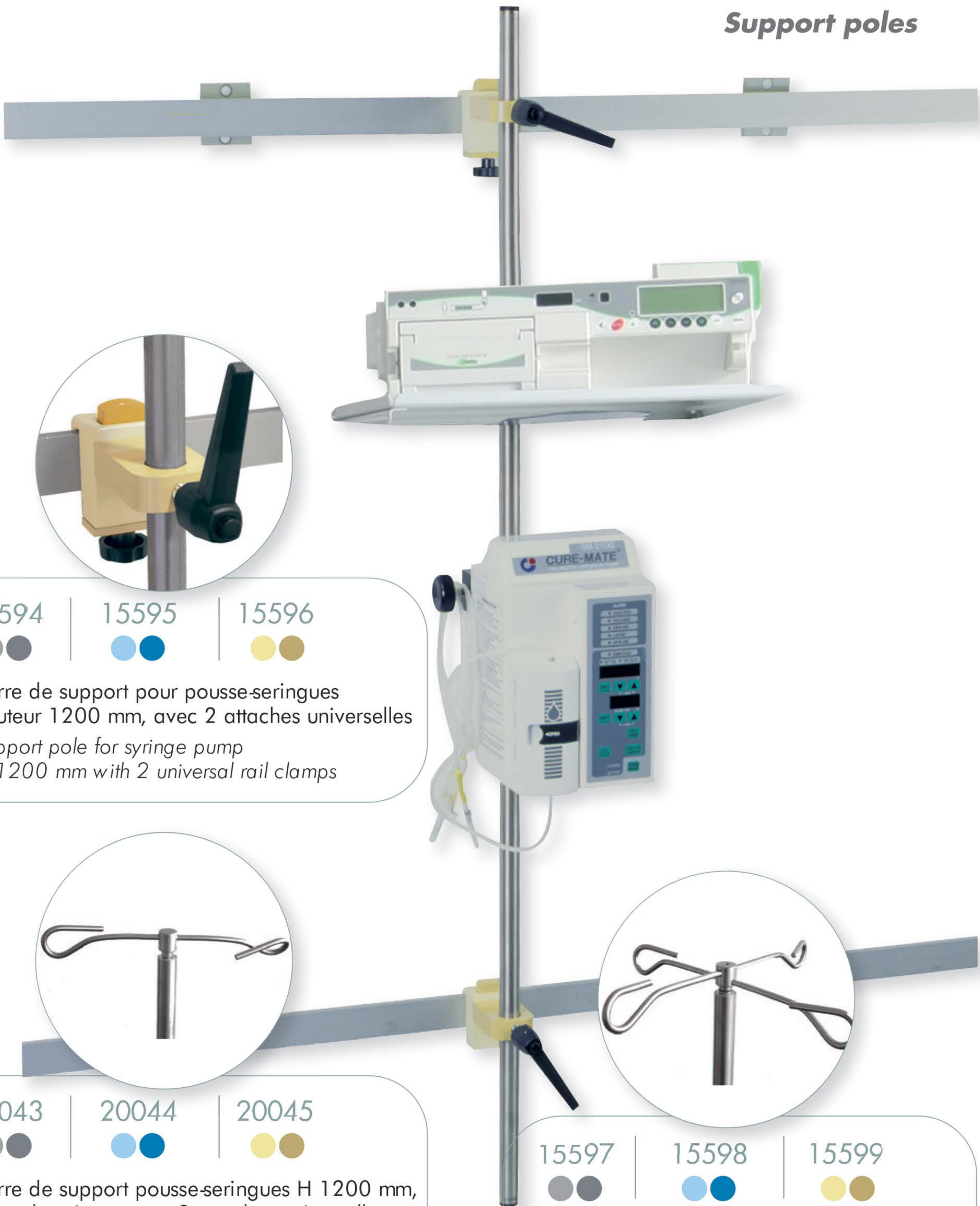

15594



15595

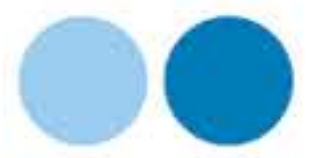

15596



- Barre de support pour pousse-seringues hauteur 1200 mm, avec 2 attaches universelles
- Support pole for syringe pump H 1200 mm with 2 universal rail clamps

20043



20044



20045



- Barre de support pousse-seringues H 1200 mm, 2 crochets inox, avec 2 attaches universelles
- Support pole for syringe pump H 1200 mm, 4 stainless steel hooks, with 2 universal clamps

15597



15598



15599



- Barre de support pour pousse-seringues H 1200 mm, 4 crochets inox, avec 2 attaches universelles
- Support pole for syringe pumps H 1200 mm with 4 stainless steel hooks and 2 universal clamps





# PORTE-BOUTEILLE

**Porte-bouteille pour petite bouteille d'urgence**  
**Diamètre maxi 145 mm. Charge maxi 6 kg**

**Cylinder holders for small emergency cylinder**  
**Maximum diameter 145 mm. Maximum load 6 kg**

## 16291 ●

- Porte-bouteille, 5 L, avec attache universelle pour montage rail
- *Cylinder holder, 5 L, with universal clamp for rail mounting*

## 16290 ●

- Porte-bouteille, 5 L, mural
- *Cylinder holder, 5 L, for wall mounting*





## Tensiomètres / Sphygmomanometers

15882

- Tensiomètre ANEROIDE orientable avec attache universelle
- *Aneroid sphygmomanometer, rotating dial with universal clamp for rail mounting*



15881

- Tensiomètre ANEROIDE, orientable, mural
- *Aneroid sphygmomanometer, rotating dial for wall mounting*





# FLEXIBLES

## FLEXIBLE RODS

### Flexibles / Flexible Rods



#### 16203 ○

- Flexible seul L 800 mm, gainé blanc, avec tige Ø 16 mm L 125 mm
- Flexible rod only, L 800 mm, white sheathed with Ø 16 mm and L 125 mm stand

#### 16204 ○

- Flexible seul L 1200 mm, gainé blanc, avec tige Ø 16 mm L 125 mm
- Flexible rod only, L 1200 mm, white sheathed with Ø 16 mm and L 125 mm stand

#### 16188 ●

- Flexible de tubes pour aérosols L 800 mm, avec support pour montant de lit
- Flexible rod, L 800 mm, with bed column mounting system

#### 16189 ●

- Flexible de tubes pour aérosols L 1200 mm, avec support pour montant de lit
- Flexible rod, L 1200 mm, with bed column mounting system

#### 16192



#### 16193



#### 16194



- Flexible de tubes pour aérosols L 800 mm avec support au rail
- Flexible rod, L 800 mm, with rail mounting clamp

#### 17289 ●

- Pince à tube aérosol, plastique, pour flexible (sachet de 5 pièces)
- Flexible rod plastic clip for aerosol tube (bag of 5 pieces)

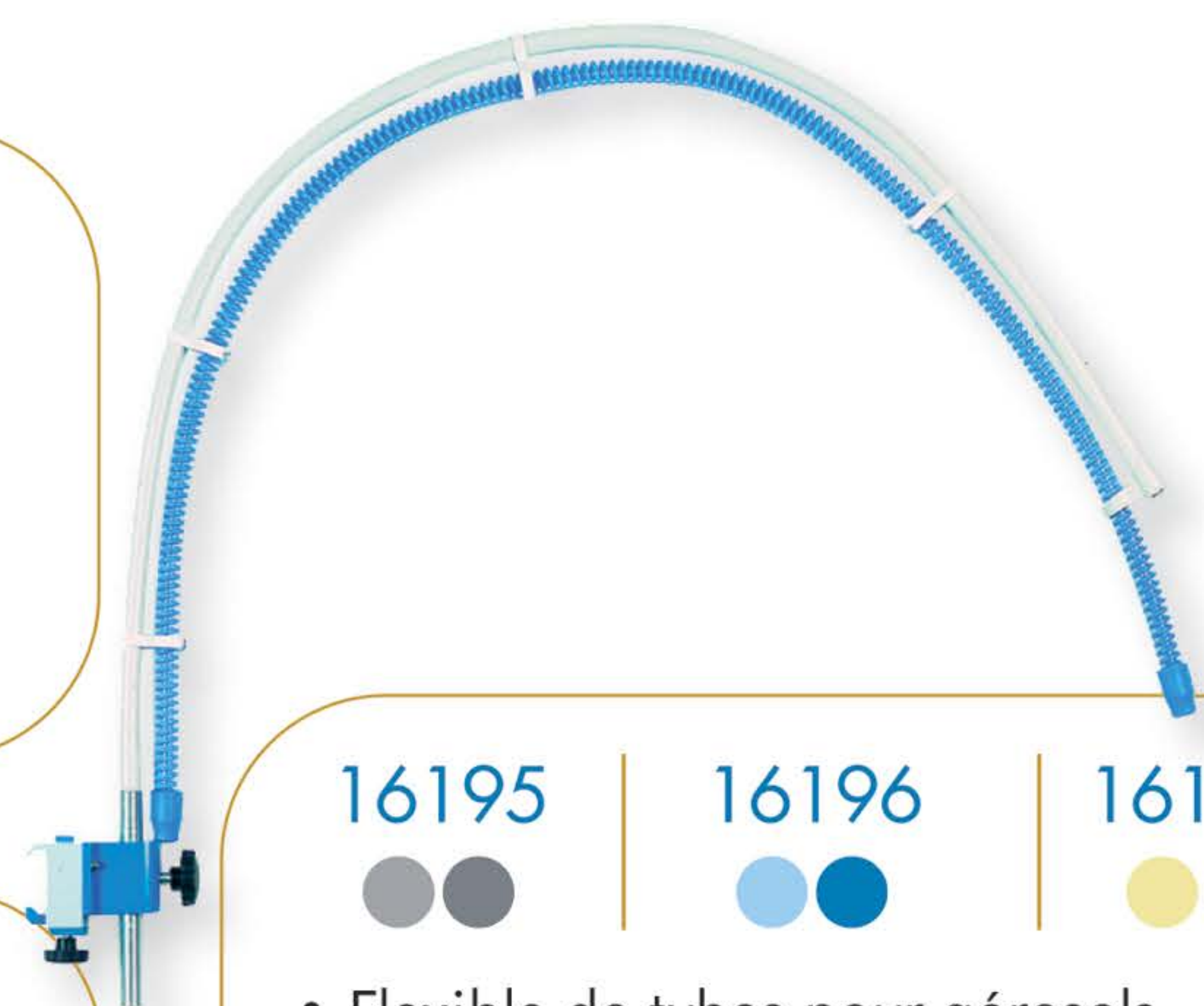

#### 16195



#### 16196



#### 16197



- Flexible de tubes pour aérosols L 1200 mm avec support au rail
- Flexible rod, L 1200 mm, with rail mounting clamp







**[dimeho@dimeho.com](mailto:dimeho@dimeho.com)**

968, av. du Général Leclerc, 47000 Agen

Tél : 05 53 98 15 18

Fax : 05 53 98 06 87

**[www.dimeho.com](http://www.dimeho.com)**

